

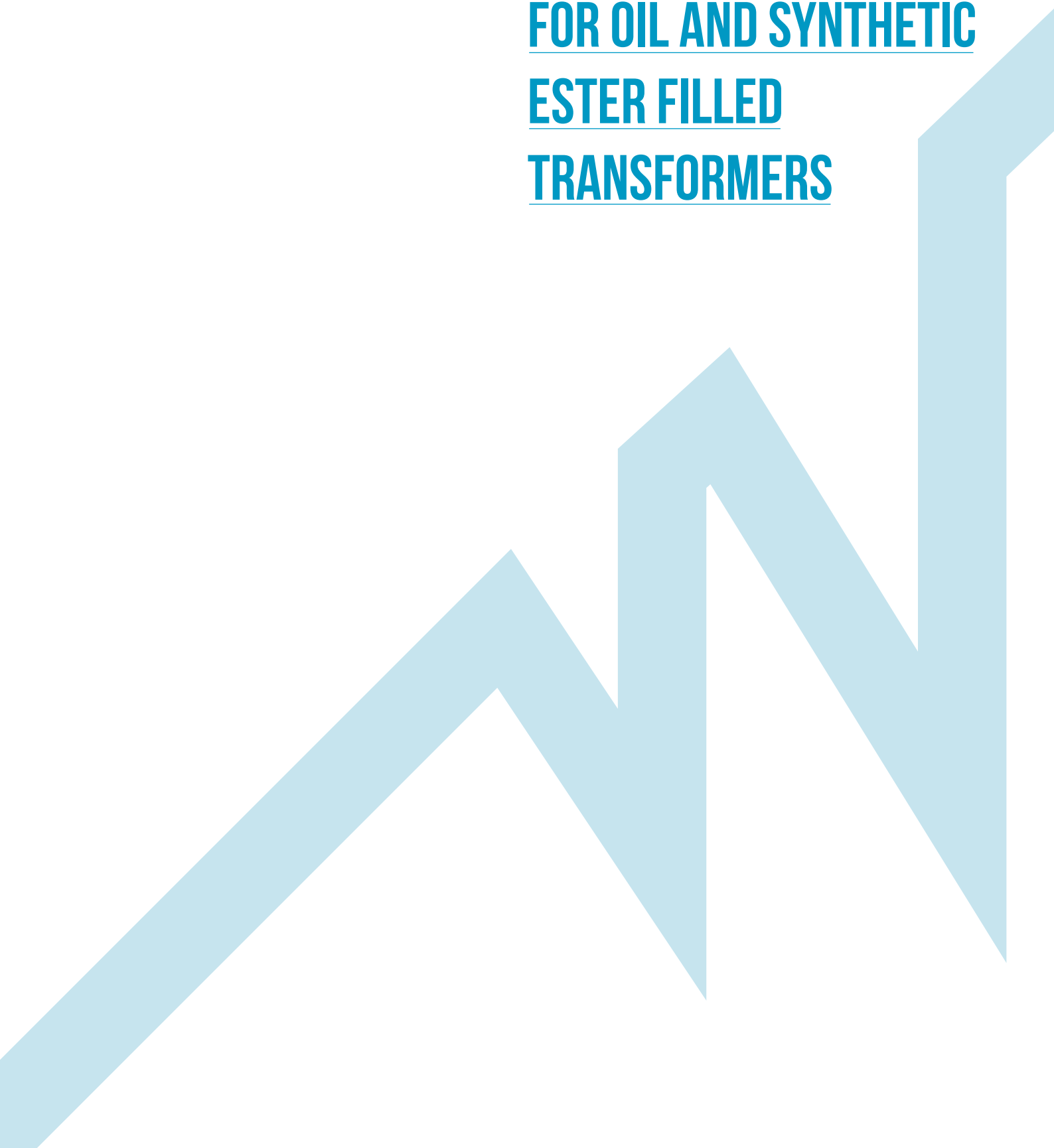

**WILSON**  
POWER SOLUTIONS

*Responsible Power Engineering*

# INSTALLATION GUIDE FOR OIL AND SYNTHETIC ESTER FILLED TRANSFORMERS



# CONTENTS

|          |  |           |
|----------|--|-----------|
| <b>1</b> | <b>INTRODUCTION</b>  | <b>03</b> |
|          | 1.1 : Cautionary note  | 03        |
|          | 1.2 : Health & Safety  | 03        |
| <b>2</b> | <b>TRANSFORMER COMPONENTS</b>                                    | <b>04</b> |
| <b>3</b> | <b>RECEIVING THE TRANSFORMER ON SITE</b>                         | <b>07</b> |
| <b>4</b> | <b>POSITIONING AND STORING THE TRANSFORMER</b>                   | <b>07</b> |
|          | 4.1 : Moving the transformer                                     | 07        |
|          | 4.2 : Storing the transformer                                    | 08        |
|          | 4.3 : Positioning the transformer                                | 08        |
|          | 4.4 : Considering fire zones for mineral oil filled transformers | 08        |
|          | 4.5 : Positioning of ester filled transformers                   | 09        |
| <b>5</b> | <b>INSTALLATION</b>  | <b>10</b> |
|          | 5.1 : Earthing the transformer                                   | 10        |
|          | 5.2 : Installing cables  | 12        |
|          | 5.3 : Installing the breather                                    | 14        |
|          | 5.4 : Connecting multicores                                      | 15        |
| <b>6</b> | <b>TESTING AND COMMISSIONING OF TRANSFORMER</b>                  | <b>17</b> |
|          | 6.1 : Pre-commissioning Transformer checks                       | 16        |
|          | 6.2 : Commissioning  | 18        |
|          | 6.2.1 : Purpose  |           |
|          | 6.2.2 : Commissioning test                                       |           |
|          | 6.3 : Post-commissioning Transformer suggestions                 | 21        |
|          | 6.4 : Transformer Life Cycle                                     | 21        |
| <b>7</b> | <b>CONTACT DETAILS</b>   | <b>21</b> |
| <b>8</b> | <b>ABOUT US</b>  | <b>23</b> |



# 1. INTRODUCTION

**All transformers supplied by Wilson Power Solutions (WPS) UK, are designed, manufactured and tested with the latest technology and under strict quality controls, in order to provide you with a long and trouble free service.**

To secure a long lifespan for the transformer it is important to follow proper installation, commissioning and protection procedures and to ensure that timely maintenance is carried out during transformer operation.

The purpose of this Installation Manual is to provide guidance on the installation and commissioning of oil-filled (mineral and synthetic ester) transformers.

This guide is necessarily generic in nature, so specific features or parts listed in this guide may be missing from your transformer, and accessories or auxiliary units on your transformer may be omitted from this guide.

In the event of any doubt, arising questions or any irregularities / deviation from IEC / BS (or equivalent) standard observed, please refer to WPS for clarification and assistance.

The transformer, along with all its accessories and fittings, should be installed, commissioned and operated under the supervision of a competent electrical engineer in accordance with relevant statutory requirements and good engineering practice, as well as being operated within the terms of the specification.

For the UK and International Standards, reference should also be made to the current edition / publication of BSI: Standards Catalogue, ENA-TS, and IEC: Catalogue of Publication, etc.

## 1.1 CAUTIONARY NOTE

No transformer should have rated service voltage applied to it until all preliminary work and pre-commissioning tests and checks have been satisfactorily completed.

No high voltage tests should be applied to any transformer without making reference to the original supplier (WPS).

A transformer which has been commissioned and then removed from service for any length of time should be re-checked to the same standard as when it was first commissioned prior to being re-energised and placed back into service.

## 1.2 HEALTH & SAFETY

Materials or components that are liable to be exposed or handled in normal operation and maintenance and could present a hazard to health are covered here.

Electricity at Work Regulations - 1989 applies to the UK Electrical Installation as per 'Memorandum of Guidance on the Electricity at Work Regulation' from HMSO.

Also, refer to the 'Regulations for Electrical Installation' BS: 7671 for installation up to 1000V AC and 'Safety in Electrical Testing' HS (G) 13 from HMSO, ISBN 011 883 283 0.

In addition to the instruction given in this manual, BS / IEC / equivalent standards and local regulation should also be referred for other details regarding the design, materials and performance.

Excessive or prolonged skin contact with transformer oil (mineral oil) should be avoided. For further information regarding oil handling, please refer to 'Effect of Mineral Oil on the Skin [SHW295]'

A list of standards applicable to distribution transformer is given as below:

- Power Transformers IEC:60076 and all relevant parts therein.
- Distribution Transformers: ENA 35-1

## 2. TRANSFORMER COMPONENTS

This section helps the user to identify individual parts of the transformer which will be referred to throughout this document. The following images will indicate the approximate location and style on several different designs.

Items labeled with a letter (A, B, C etc.) indicate standard components are present on all standard transformers, numbers (1, 2, 3 etc.) indicate optional extras or accessories that may not be on your version.

### STANDARD COMPONENTS AND ACCESSORIES:

- A. Connection point for air dehydrating breathers (Figure 1a)
- B. LV connection (standard cable connection) (Figure 1a)
- C. Marshalling Box (Figure 1a)
- D. Drain valve (Figure 1a)
- E. De-energised tap-changer (Figure 1a & Figure 2)
- F. Thermometer pocket (Figure 1a)
- G. Rating plate (Figure 1a)
- H. Jacking points (Figure 1a)
- I. Transformer lifting eyes (Figure 1b)
- J. Tank earthing terminals (Figure 1b)
- K. Transformer lid lifting eyes (Figure 1b)
- L. Radiators (Figure 1b)
- M. HV connection (standard cable connection) (Figure 2)

### OPTIONAL COMPONENTS AND ACCESSORIES:

1. Oil temperature indicator (OTI)/ Winding temperature indicator (WTI) (Figure 1a)
2. Ring main units/ACB/ other connections (Figure 1a)
3. Thermometer, to install on the thermometer pocket (Figure 1a)
4. Pressure relief device (PRD) (Figure 1b)
5. Current transformer connection box (Figure 1b)
6. Conservator (Figure 1b)
7. Buchholz relay (Figure 1b)
8. Off circuit dual ratio changer (Figure 2)
9. Oil level indicator (Figure 2)

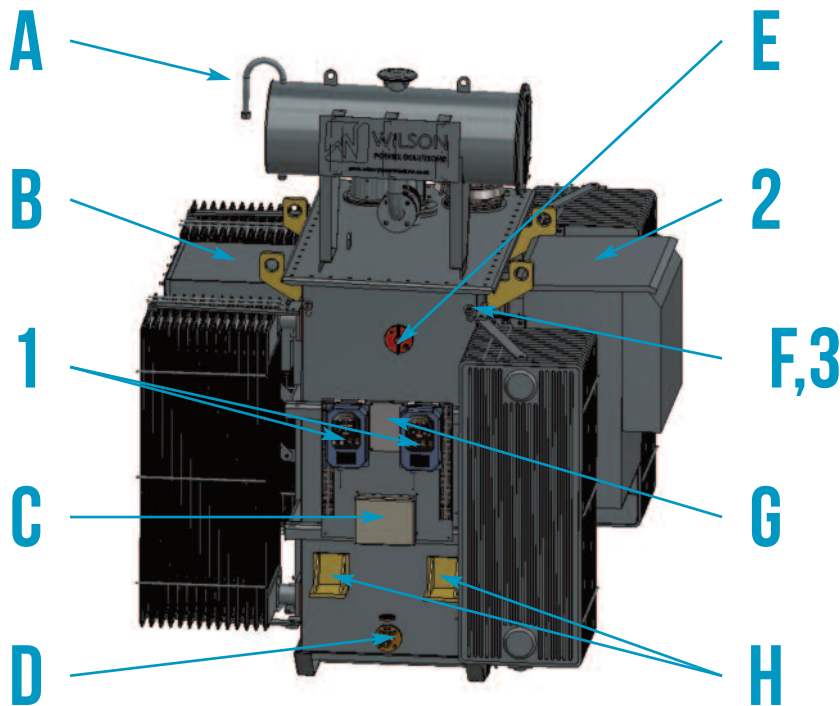

Figure 1a - Transformer View from Tap Switch End

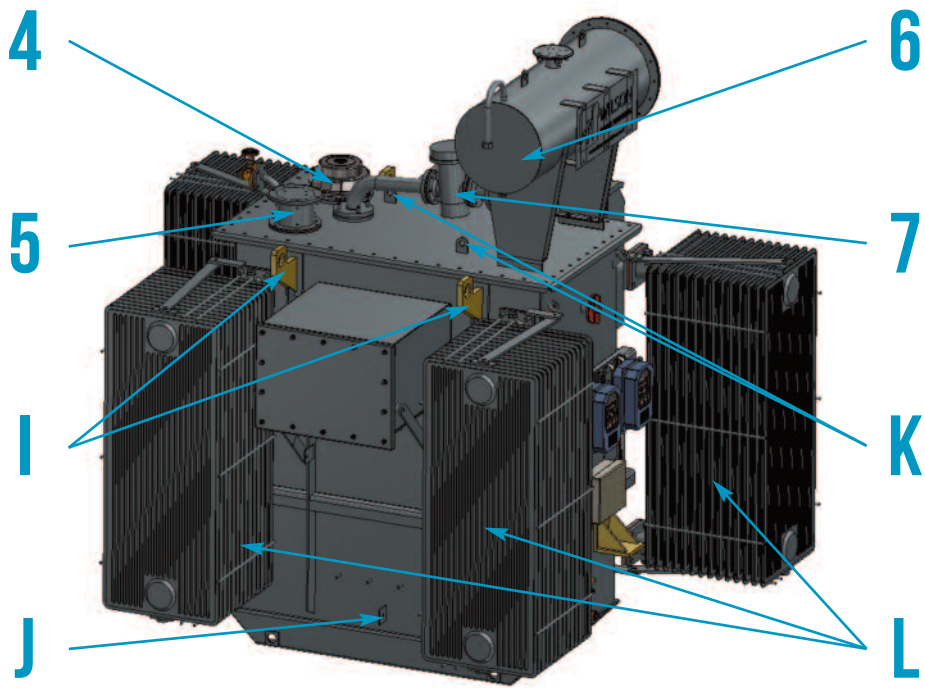

Figure 1b - Transformer View from LV Side

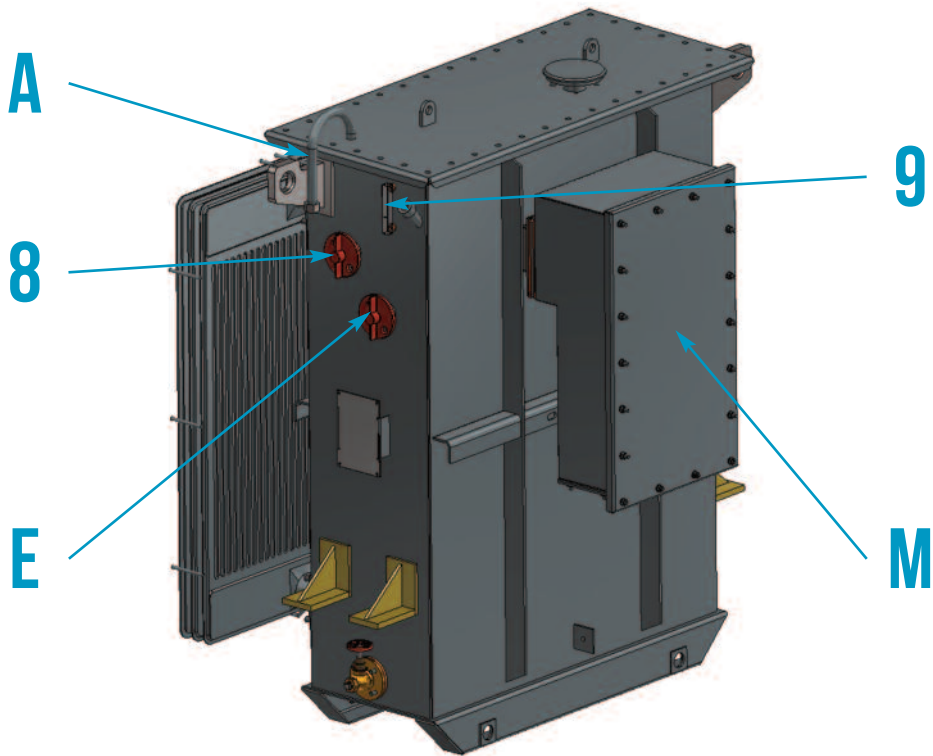

Figure 2 - Dual Ratio Transformer

## 3. RECEIVING THE TRANSFORMER ON SITE

The transformer is generally supplied fully assembled and ready to be connected to the medium and low voltage line.

On receipt of the transformer, both at the client's plant or at site, it is necessary to carry out the following checks:

**DATE RECEIVED:** \_\_\_\_\_

# CHECKLIST

### RECEIVING TRANSFORMER ON-SITE CHECKLIST

| PART            | ITEM TO BE CHECKED  | Y/N |
|-----------------|---|-----|
| Main Tank       | Check there are no signs of damage on the transformer that may have occurred during the transport.                            |     |
| Main Tank       | Check to make sure that there is no damage to the paint work and that there is no rust present on the transformer.            |     |
| Main Tank       | Check that the characteristics of the transformer detailed on the rating plate correspond to those of the shipping documents. |     |
| Accessories     | Check each transformer is complete with the accessories stipulated in the contract (WTI, PRD, etc.).                          |     |
| Terminations    | Check that all connections are clean and all bushings or connectors are free from cracks or breakage (if applicable).         |     |
| Marshalling Box | Check there is no damage and all connections are correctly made and undamaged.  |     |

**IMPORTANT:** In the case that any anomalies are found, immediately contact WPS. It will be assumed that the transformer has been delivered in perfect condition unless any notification is given within 7 days that suggests otherwise. WPS, therefore, cannot be considered responsible either for what could happen to the transformer during service or for the resulting consequences.

## 4. POSITIONING & STORING THE TRANSFORMER

Before positioning the transformer, ensure that its intended location will have the following characteristics:

- Provision for spatial requirement and ancillary items detailed on corresponding drawings that can be found in this section.
- Adequate ventilation.
- Ambient temperature within the normal operating range, compliant with IEC 60076-1, Section 4 "Service Conditions".
- Protection against exposure to fire, excessive moisture, explosion, etc.
- Provision for regular inspection, maintenance.

The transformer should always be moved and stored in line with the "Transformer handling and storage guide", which will be provided with the transformer. The instructions within this section should always be adhered to when performing tasks pertaining to the transformer.

### 4.1 MOVING THE TRANSFORMER

Read through the following guidelines before undertaking any movement of the transformer on site.

- Under no circumstances should the transformer be moved with a fork lift. All lifting should be done by either slinging or jacking with the appropriate connections which are indicated with yellow paint and can be identified in Figure 3.

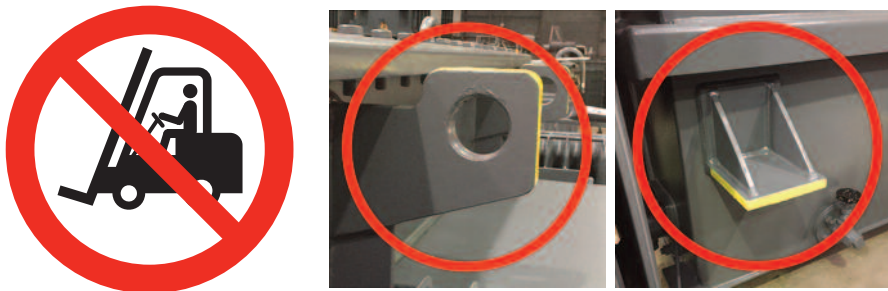

Figure 3 - Lifting Guide

- When moving the transformer by slinging the centre of gravity might not be central to the transformer and it may be top heavy. It is important that the transformer is lifted correctly. All slings or chains should be properly positioned and not make contact with the cable boxes or radiators as shown in Figure 4.
- It is important to note that the total weight indicated on the transformer rating plate will not include any ring main units/ACB or other added items. The complete assembled weight can be found on the transformer handling and storage guide in the yellow box in the bottom right hand corner, stating the shipping weight as shown in Figure 5. If there is any uncertainty, identify all rating plates on the transformer and accessories, add the weights together and add a suitable safety factor of no less than 10%.



Figure 4 – Slings instructions



**SHIPPING WEIGHT (KGS)**

---

Figure 5 – Total weights

- When moving the transformer via crane it is important to ensure the chains are at the correct length and angle, to ensure the transformer is not damaged.

On transformers with a conservator (or with 4 lifting lugs) use 4x1500mm chain held at a 35 degree angle (see figure 5a). For a transformer without a conservator use 2x1500mm chains at an angle of 58 degrees (see Figure 5b).

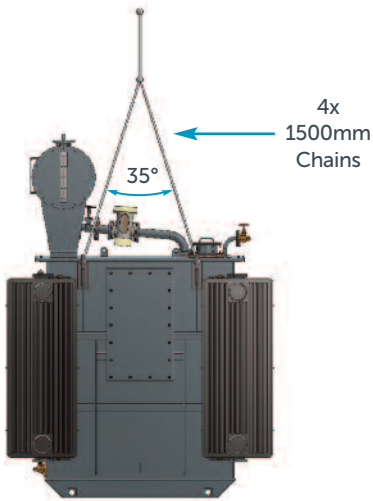

Figure 5a – Transformer with Conservator

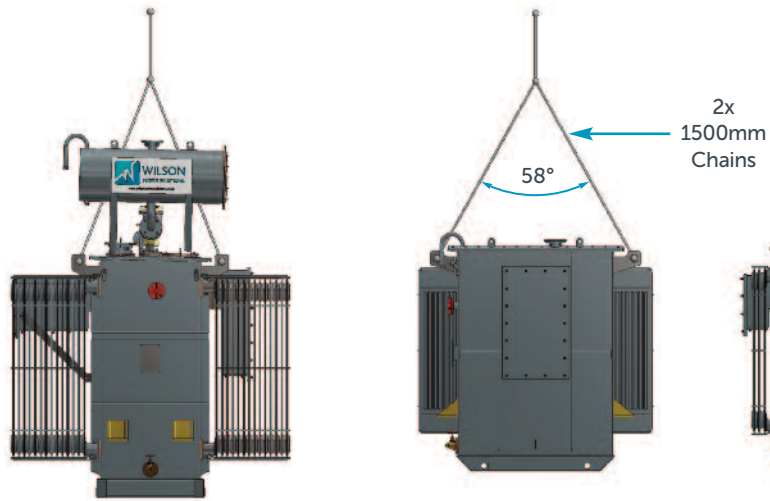

Figure 5b – Transformer without Conservator

## 4.2 STORING THE TRANSFORMER

Please comply with the following guidelines when storing the transformer:

- Ensure that the transformer is stored on a flat surface.
- If the storage time exceeds 2 weeks then the breather must be fitted (see section 5.3 in this manual).
- Precautions:
  - Transformer oil becomes flammable at 140 degrees, however under certain circumstances and in confined spaces the oil/oil vapour may become explosive. This means that naked flames should never be brought or kept near the transformer.
  - If any external cleaning or wiping is necessary, it should be done with a clean and dry cloth.

## 4.3 POSITIONING THE TRANSFORMER

Ensure that consideration is given to measures such as fire zones and fire barriers prior to the delivery of the transformer. If in doubt consult the appropriate authority.

## 4.4 CONSIDERING FIRE ZONES FOR MINERAL OIL FILLED TRANSFORMERS

Due to the size of distribution transformers the following equation can be used to calculate the fire zone

$$\text{SEPARATION DISTANCE} = \text{FIRE POOL DIAMETER} + 1\text{M}$$

Separation distance and fire pool diameter can be taken from the opposite page in Figure 6.



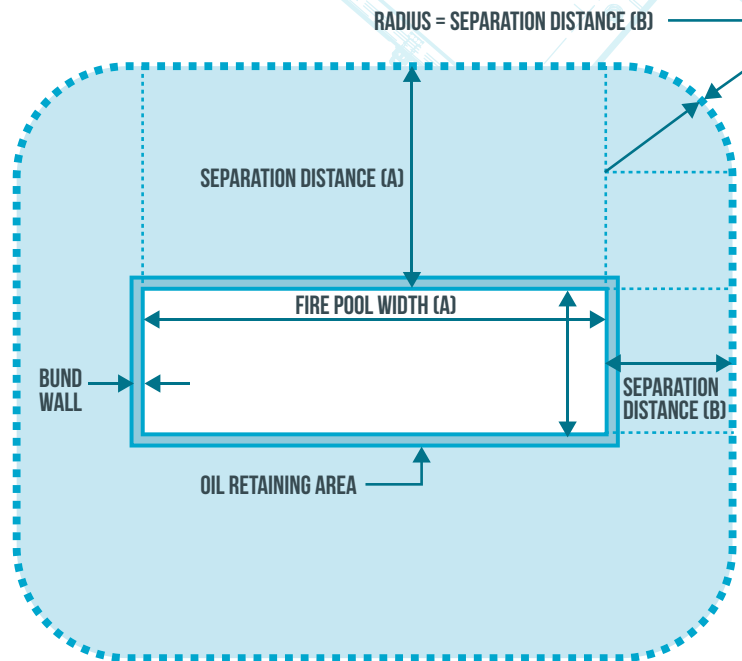

Figure 6 - Fire damage zone

## 4.5 POSITIONING OF ESTER FILLED TRANSFORMERS

Due to the characteristic of esters, fire zones do not need to be considered. However, a gap of one metre (1m) must be left between transformers for access and to guarantee no reduction of cooling capability.

When positioning transformers next to each other it is important that the outmost boundary does not encroach upon the next transformer tank. Figure 7 illustrates the minimum clearance required to safely position adjacent transformers.

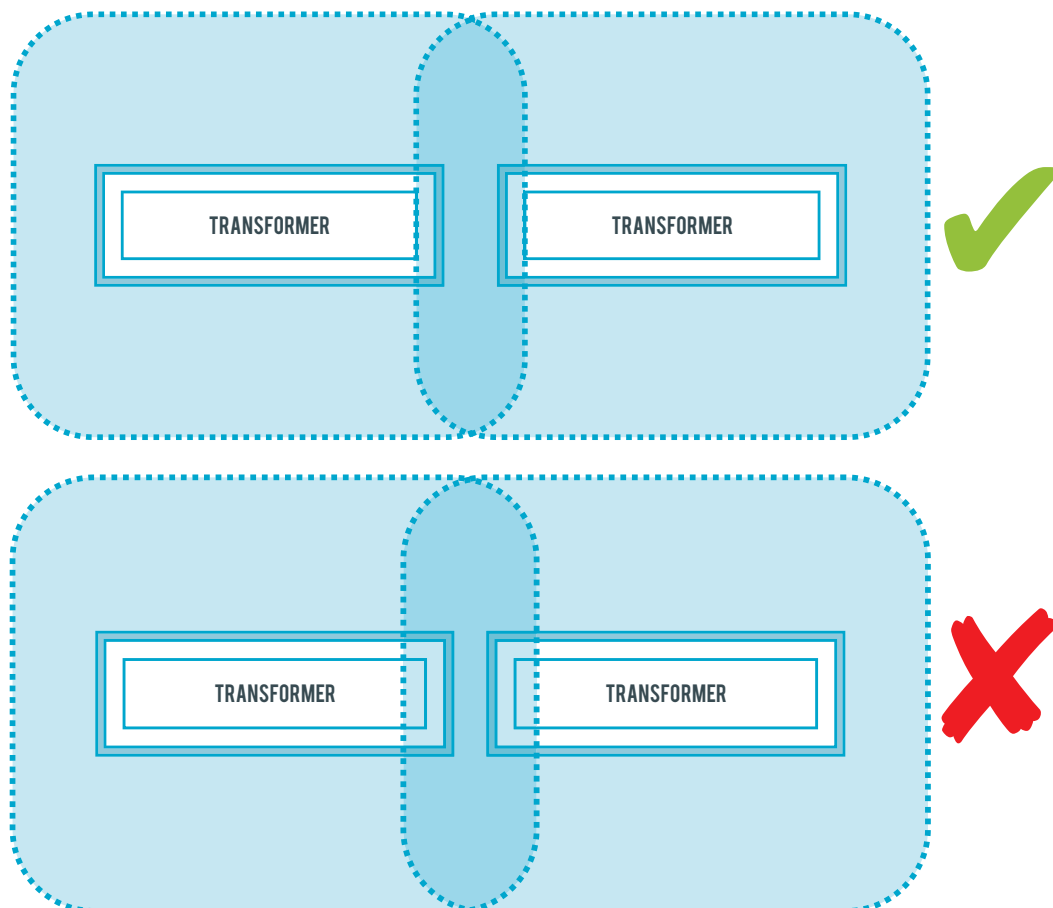

Figure 7 – Correct and incorrect ways of positioning transformers

## 5. INSTALLATION

The following is a guide for the installation of our standard designs to a site with unhindered access to the equipment. In the event that your site does not allow for unhindered access, analyse the risks before proceeding.

### 5.1 EARTHING THE TRANSFORMER

The following section explains how to earth the transformer to the substation earth mat. If the transformer is in the vicinity of live equipment i.e. cables, then applying the earth should be done before any other work is commenced. Figure 8 below shows the connection with appropriate earthing connection.

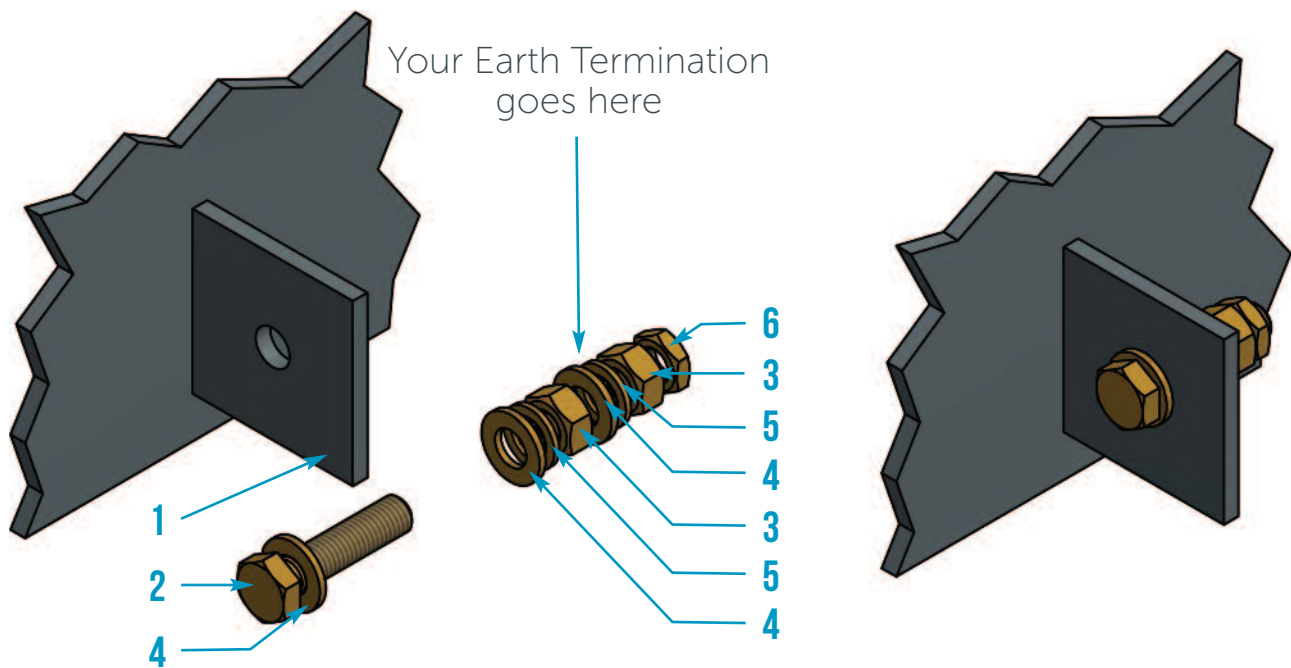

Figure 8 - Earthing connection construction

#### PARTS LIST FOR EARTHING CONNECTION

| ITEM | QTY | DESCRIPTION                 | ITEM | QTY | DESCRIPTION                  |
|------|-----|-----------------------------|------|-----|------------------------------|
| 1    | 1   | Earthing Terminal           | 4    | 3   | M12- Washer – Flat - Brass   |
| 2    | 1   | M12- Hex Set – Brass        | 5    | 2   | M12- Washer – Spring – Brass |
| 3    | 2   | M12- Hex Nut – Full - Brass | 6    | 1   | M12- Hex Nut – Half - Brass  |

# EARTHING THE TRANSFORMER

## TRANSFORMER EARTHING PROCESS

Y/N

The transformer will be delivered with the above earthing connection assembly, if this is not the case inform WPS.

It is advised that the sets (nuts, bolts & washers) are removed and the surfaces are inspected to make sure they are clear from paint, dirt or other substances to ensure a good connection.

If the transformer has been stored for more than two weeks it is advised that the surface is re-cleaned to show a shiny bare metal surface.

Reinsert the sets (nuts, bolts & washers).

Ensure the earth cable/tape is suitable to be connected to an M12 sets (nuts, bolts & washers) by either solution, shown below:



For Flat Bar



For Cable

Place the earthing cable onto the sets (nuts, bolts & washers) and apply the remaining washer and nut. Torque to 30Nm with a calibrated torque wrench.

This process needs to be carried out on both tank earthing terminals.

## 5.2 INSTALLING CABLES

The following section provides guidance on installing cable(s) in a standard cable box.

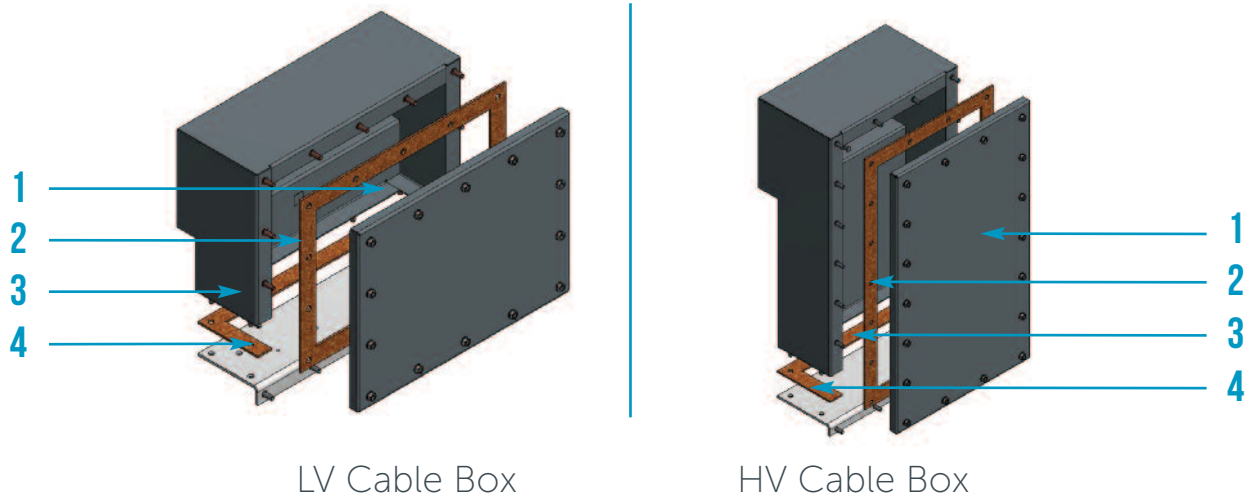

Figure 9 - Cable box construction

The transformer will typically be delivered with the cable boxes fully assembled and connected to the transformer. The following steps should be taken when fitting the cable(s).

### PARTS LIST FOR CABLE BOX

| ITEM | QTY | DESCRIPTION            | ITEM | QTY | DESCRIPTION        |
|------|-----|------------------------|------|-----|--------------------|
| 1    | 1   | Cable Box Cover        | 3    | 1   | Gland Plate Gasket |
| 2    | 1   | Cable Box Cover Gasket | 4    | 1   | Gland Plate        |

# CHECKLIST

## INSTALLING CABLES

### CABLE INSTALLATION PROCESS

Y/N

Visually inspect the cable boxes to make sure there is no damage.  
If the cable box is found to be damaged do not proceed, contact WPS.

Remove the M10 sets (nuts, bolts & washers) on the cable box cover (1) and slide/lift off the cable box cover from the cable box. Store all items in a clean, dry, safe place.

Remove the gasket (2) and store in a clean, dry place.

Visually inspect the inside of the cable boxes to make sure there is no damage. If the cable box is found to be damaged do not proceed, contact WPS.

Remove the M10 sets (nuts, bolts & washers) which connect the gland plate (4) to the cable box (make sure the gland plate is supported to prevent falling).

Remove the gasket (3) and store in a clean, dry place.

Cut suitable sized holes in the gland plate (4) to feed the cables (pilot holes have been provided in line with the connection points). Make sure there is enough cable to reach the terminal and to prepare for connection. **Note – This is not a load bearing termination. Use correct glands to provide support.**

Reattach the gasket (3) to the gland plate (4).

Reattach the gland plate (4) to the cable box and tighten all sets (nuts, bolts & washers). Ensure that each cable is connected to the correct phase. Unless otherwise stated, the phase orientation working left to right will be:

HV – 1N\*, 1U, 1V, 1W

LV – 2U, 2V, 2W, 2N\*

\*Phase rotation is correct where neutral is present.

Prepare the cable for connection.

LV: Where possible all cables should be connected on the same side;



HV connection should be tightened to 19Nm using a calibrated torque wrench.  
LV connection should be tightened as per your fixing guidance.

Ensure the cable box is clean and dry on the inside before reclosing.

Reattach the gasket (2).

Reattach the cover (1) and torque to 25Nm.

### 5.3 INSTALLING THE BREATHER

The following section is a guide for installing the breather.



Figure 10 – Breathers

Without Conservator

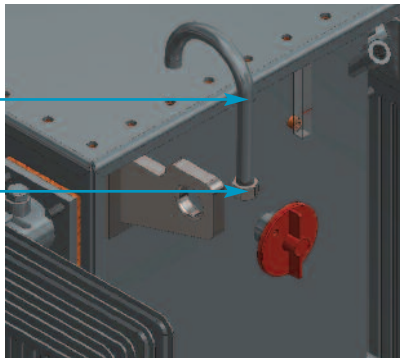

With Conservator

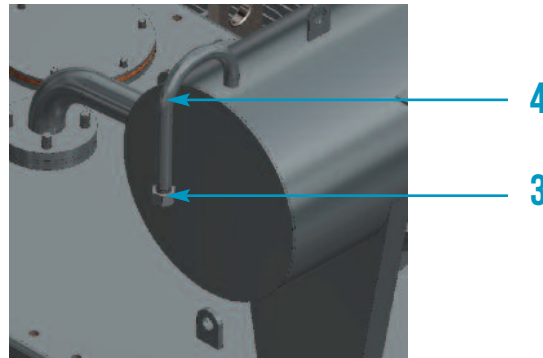

Figure 11 – Breather connection point

Once the breather has been fitted, do not move the transformer. If you wish to move the transformer, uninstall the breather and reapply the end cap.

#### PARTS LIST FOR BREATHER CONNECTION

| ITEM | QTY | DESCRIPTION | ITEM | QTY | DESCRIPTION           |
|------|-----|-------------|------|-----|-----------------------|
| 1    | 1   | Plastic Cap | 3    | 1   | Breather Pipe End Cap |
| 2    | 1   | Breather    | 4    | 1   | Breather Pipe         |

# CHECKLIST







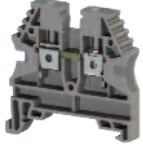

## INSTALLING THE BREATHER

### BREATHER INSTALLATION PROCESS

|  | Y/N |
|--|-----|
| Check that the contents of the breather (2) are orange - if you notice any other colour besides orange within the breather inform WPS.                         |     |
| Remove the plastic cap (1) from the breather.  |     |
| Remove the breather end cap (3) from the pipe and clean the threads if required. Store end cap safely for re-use.  |     |
| Connect the breather to the breather pipe (4).<br>Note – Only hand-tighten the breather, do not tighten with tools as there is a risk of cracking the plastic. |     |

## 5.4 CONNECTING MULTICORES

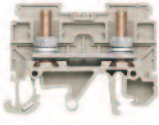
The standard terminals within the marshalling box can be identified as follows:

| PARTS LIST FOR BREATHER CONNECTION |                       |   |                 |        |   |
|------------------------------------|-----------------------|---|-----------------|--------|---|
| APPLICATION                        | TERMINAL              | IMAGE   | TERMINAL        | TORQUE | IMAGE   |
| Alarms & trips                     | 4mm terminal          |    | Bootlace Crimp  | 0.6Nm  |    |
| Earth                              | 6mm screw terminal    |    | Bootlace Crimp  | 0.6Nm  |    |
| CT terminals                       | 6mm CT link terminals |   | Bootlace Crimp  | 1.6Nm  |    |
| CT earth terminals                 | Stud type terminal    |  | Ring Type Crimp | 2.0Nm  |  |

# CHECKLIST

## CONNECTING MULTICORES

### MULTICORE CONNECTION PROCESS

Y/N

Remove the lid of the marshalling box and store in a safe place. If the marshalling box is damaged inform WPS.

Locate a space on the box where you intend for the cables to enter the box. (WPS recommend to use the under section of the box).

Drill a hole through the enclosure to accommodate the cable and the gland.

Each multicore cable is to be crimped in accordance with the table above.

Terminate the cables in the correct terminal in accordance with the wiring diagram.

Check all cables have been secured on both sides of the terminals.

Reposition the lid of the marshalling box and retighten clamps.



# 6. TESTING AND COMMISSIONING OF THE TRANSFORMER

If these instructions are followed, the transformer can be safely put into service after commissioning is completed.

IMPORTANT: All checks to be carried out by a suitably qualified technician or engineer.



## CHECKLIST

### 6.1 PRE-COMMISSIONING TRANSFORMER CHECKS:

| PART                          | ITEM TO BE CHECKED   | Y/N |
|-------------------------------|--|-----|
| De-energised Tap Changer      | The transformer will be delivered with the tap position on the principle tap, you may alter this if another tap setting is required. Once the desired tap has been chosen it must be locked and the key must be stored in a safe place to reduce the chance of maloperation. |     |
| Tank Earthing Terminals       | Ensure you have connected your earth mat to the transformer via the tank earthing terminal, using the process detailed in section 5.1.   |     |
| Thermometer Pocket            | Ensure that all thermometer pockets are fitted with appropriate equipment (such as a temperature sensor) or closed off via a cap.<br>   |     |
| Drain Valve                   | The transformer will be delivered filled with insulating fluid, with the drain valve closed and a cap covering it as shown below:<br><br>If this is not the case inform WPS.              |     |
| Breather                      | Confirm the breather has been installed in line with section 5.3   |     |
| Oil temperature indicator     | The transformers will be delivered with a preset alarm and trip as shown below:<br>OTI: Alarm 90oC, Trip 100 oC<br>If other alarm and trip values are required, refer to their product manuals for installation guidelines.  |     |
| Winding temperature indicator | The transformers will be delivered with a calibrated, preset alarm and trip as shown below:<br>WTI: Alarm 100oC, Trip 110 oC<br>If other alarm and trip values are required, refer to their product manuals for installation guidelines.                                     |     |

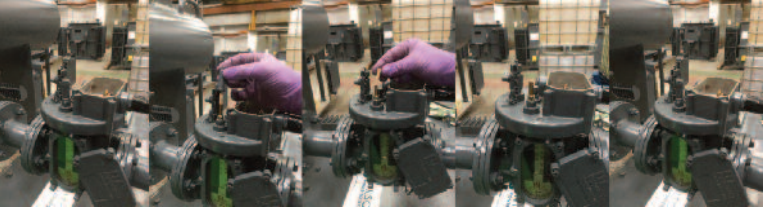
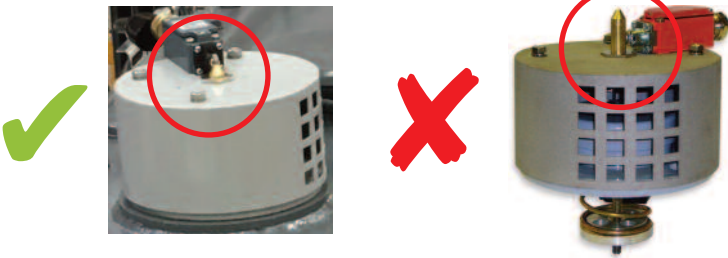

# CHECKLIST

| PART                           | ITEM TO BE CHECKED   | Y/N                        |  |  |            |                 |             |       |     |     |      |     |              |  |
|--------------------------------|--|----------------------------|--|--|------------|-----------------|-------------|-------|-----|-----|------|-----|--------------|--|
| Buchholz relay                 | Visually check that the device is completely filled with oil.<br>Ensure that the woodblock has been removed from under the cap as below:   |                            |  |  |            |                 |             |       |     |     |      |     |              |  |
|                                |    |                            |  |  |            |                 |             |       |     |     |      |     |              |  |
| Pressure relief device         | Ensure the device has not been operated. The brass coloured pin should be in the down position, as illustrated below:  |                            |  |  |            |                 |             |       |     |     |      |     |              |  |
|                                |   |                            |  |  |            |                 |             |       |     |     |      |     |              |  |
| Dual secondary voltage changer | The transformer will be delivered set to the lower voltage unless requested otherwise. If lower voltage is not what you require, ensure the tap is changed to the appropriate setting. The number that corresponds to the tap position is indicated on the rating plate "SELECTOR SWITCH CONNECTION" and "SWITCH POSITION" as shown below:               |                            |  |  |            |                 |             |       |     |     |      |     |              |  |
|                                | <table border="1" data-bbox="481 1209 750 1420"> <thead> <tr> <th colspan="3">SELECTOR SWITCH CONNECTION</th> </tr> <tr> <th>HV VOLTAGE</th> <th>SWITCH POSITION</th> <th>TAPS JOINED</th> </tr> </thead> <tbody> <tr> <td>11000</td> <td>HV1</td> <td>3-4</td> </tr> <tr> <td>6600</td> <td>HV2</td> <td>1-4<br/>&amp; 3-5</td> </tr> </tbody> </table> | SELECTOR SWITCH CONNECTION |  |  | HV VOLTAGE | SWITCH POSITION | TAPS JOINED | 11000 | HV1 | 3-4 | 6600 | HV2 | 1-4<br>& 3-5 |  |
| SELECTOR SWITCH CONNECTION     |  |                            |  |  |            |                 |             |       |     |     |      |     |              |  |
| HV VOLTAGE                     | SWITCH POSITION  | TAPS JOINED                |  |  |            |                 |             |       |     |     |      |     |              |  |
| 11000                          | HV1  | 3-4                        |  |  |            |                 |             |       |     |     |      |     |              |  |
| 6600                           | HV2  | 1-4<br>& 3-5               |  |  |            |                 |             |       |     |     |      |     |              |  |
|                                | Once the correct voltage has been chosen, check that the switch has been securely into that position.  |                            |  |  |            |                 |             |       |     |     |      |     |              |  |
| Oil level indicator            | The oil level indicator can either be a magnetic oil gauge (right) or a standard visual indicator (left). Make sure that the oil is in line with the expected temperature.   |                            |  |  |            |                 |             |       |     |     |      |     |              |  |
|                                | If no oil level can be determined stop all activities and inform WPS.  |                            |  |  |            |                 |             |       |     |     |      |     |              |  |
|                                |   |                            |  |  |            |                 |             |       |     |     |      |     |              |  |

## 6.2 COMMISSIONING

### 6.2.1 PURPOSE

After the satisfactory completion of installation and pre-commissioning checks the following tests must be performed before putting the transformer into service. Prior to commissioning work refer to the manufacturer's instruction booklet / product catalogue, etc. for specific help and information on any accessories supplied. These can be provided on request from WPS.

### 6.2.2 COMMISSIONING TEST

# CHECKLIST

## INSULATION RESISTANCE (IR) TEST

### COMMISSIONING PROCEDURE

Y/N

Before starting this test ensure that all power terminal bushings have been thoroughly cleaned with a clean, dry piece of cloth.

During IR test, no external power lines / cables, lightning arresters, neutral earthing, etc., should be in the power circuit. Ensure that the transformer is completely isolated at both HV & LV sides and that all non-current carrying conductors are earthed.

The IR values of windings to earth (and between windings) shall be measured for all tap positions.

Between HV Winding and Earth use 5000V or 2500V Insulation Tester (Megger)

Principle Tap Value: \_\_\_\_\_

Between HV and LV Winding use 5000V or 2500V Insulation Tester (Megger)

Principle Tap Value: \_\_\_\_\_

Between LV Winding and Earth use 1000V or 500V Insulation Tester (Megger)

Value: \_\_\_\_\_

The IR values obtained should be similar to those indicated in the manufacturers' test report, which will have been furnished with the handing-over documents. Be aware that in humid conditions IR values obtained may be lower due to condensation on the terminal bushings.

If IR values are very low (Minimum value is 1000ohm per volt service voltage), then it may be necessary to filter the oil / dry-out the winding till the insulation reaches satisfactory values.

## BREAK-DOWN VOLTAGE (BDV) TEST

### PROCEDURE

Y/N

Oil samples should be carefully taken from the tank bottom and tested for BDV value.

BDV value of oil should be more than 50kV (rms) for 1 minute in standard test cell.

Value: \_\_\_\_\_

If the BDV value is very low and unacceptable (30kV (rms) or less for 1 minute) then it may be necessary to dry-out & clean the oil until the insulation reaches satisfactory values.

Note: For very low IR values and low BDV values, it is recommended to contact WPS for a suitable recovery procedure based on available facilities at site.

# CHECKLIST

## VOLTAGE RATIO TEST

### PROCEDURE

Y/N

Apply 3-Phase, 433V/415V AC or a single phase 240V/230V AC supply on the HV side and the Voltage Ratio at all tap positions. This can be derived using a suitable precision voltmeter connected to the LV side. A ratio meter, if available, can be used for a more accurate measurement.

Tap 1 ratio: .....

Tap 2 ratio: .....

Tap 3 ratio: .....

Tap 4 ratio: .....

Tap 5 ratio: .....

Tap 6 ratio: .....

The Ratio values obtained should be similar to those indicated in the manufacturer's test report, which will have been furnished with the handing-over documents.

## WINDING RESISTANCE MEASUREMENT TEST

### PROCEDURE

Y/N

Winding Resistance of every phase of each winding should be measured using suitable DC Resistive Bridge or similar.

HV U Value: .....

HV V Value: .....

HV W Value: .....

LV u Value: .....

LV v Value: .....

LV w Value: .....

Winding Resistance values obtained should be similar to those indicated in the manufacturer's test report, which will have been furnished with the handing-over documents.

# CHECKLIST

## MARSHALLING BOX SCHEME CHECK

### PROCEDURE

Y/N

All the auxiliary wiring from the various accessories to the marshalling box shall be checked against the marshalling box scheme drawing provided.

Operation of all the alarm / trip contacts should be checked by simulating the alarm or trip condition, checking that the alarm or trip signal appears at the correct terminal at the marshalling box.

## BUCHHOLZ RELAY TEST

### PROCEDURE

Y/N

The Relay operation for alarm and trip contacts should be checked by injecting air through the test petcock. The air injected into the relay will allow the alarm float / flap and trip float / flap to fall thus operating their respective switches.

## TEMPERATURE INDICATOR TEST

### PROCEDURE

Y/N

Indicator operation for alarm and trip contact shall be checked by manual stimulation.

## DE-ENERGISED TAP SELECTOR (OCS)

### PROCEDURE

Y/N

During shipment the OCS is not separated from the transformer, so it is not necessary to recheck the internal connections of tapping and internal mechanism.

Means of protecting the OCS from unauthorised operation is provided by using pad locking arrangement at designated tap position.

## FLASH TEST ON WINDING (ON THE REQUEST OF THE CUSTOMER)

### PROCEDURE

Y/N

If a flash test is required then it must be performed at reduced voltages only, which is value calculated by subtracting the service voltage from the original test voltage as tested as per the manufacturer's test certificate, halving the obtained value and then adding the service voltage as explained in this example:

Service Voltage 11kV

Half of Difference Voltage

Recommended Test Voltage at site  $(17 / 2 = 8.5\text{kV}) + 11 = 19.5\text{kV}$

## 6.3 POST-COMMISSIONING RECOMMENDATIONS

It is recommended that the transformer is initially energised at No-load only and is checked for any abnormalities for the next 6 to 8 hours.

After switching on No-load, if the primary side circuit breaker is tripped, investigate the cause thoroughly and re-energise the transformer only after ensuring that any fault is properly identified and cleared.

If satisfactory (transformer on No-Load) then apply load gradually and observe for any abnormalities for the next 6 to 8 hours.

If the transformer is satisfactory on-load up to 50% for the first 4-8 hours, shut-down the transformer and ensure that all air-release plugs of tank, radiator, conservator, buchholz relay, bushings, etc., are free of air pockets which might have developed during initial loading.

## 6.4 TRANSFORMER LIFE CYCLE

Transformers are made from a mix of ferrous and non-ferrous metals which are widely recyclable, as is the insulating medium. We recommend that end of life units are disposed of by means of recognised waste handlers / dismantler. This product does not come under WEE regulations.

NOTE: Suitable financial value can be obtained, particularly for copper. Alternatively, aluminium can be used as a winding conductor.

# 7. CONTACT DETAILS

If you need to contact us for any reason please use the following:

**TELEPHONE:** +44 (0)113 271 7588

**EMAIL:** [info@wilsonpowersolutions.co.uk](mailto:info@wilsonpowersolutions.co.uk)

**ADDRESS:** Westland Works, Westland Square, Leeds, West Yorkshire, LS11 5SS

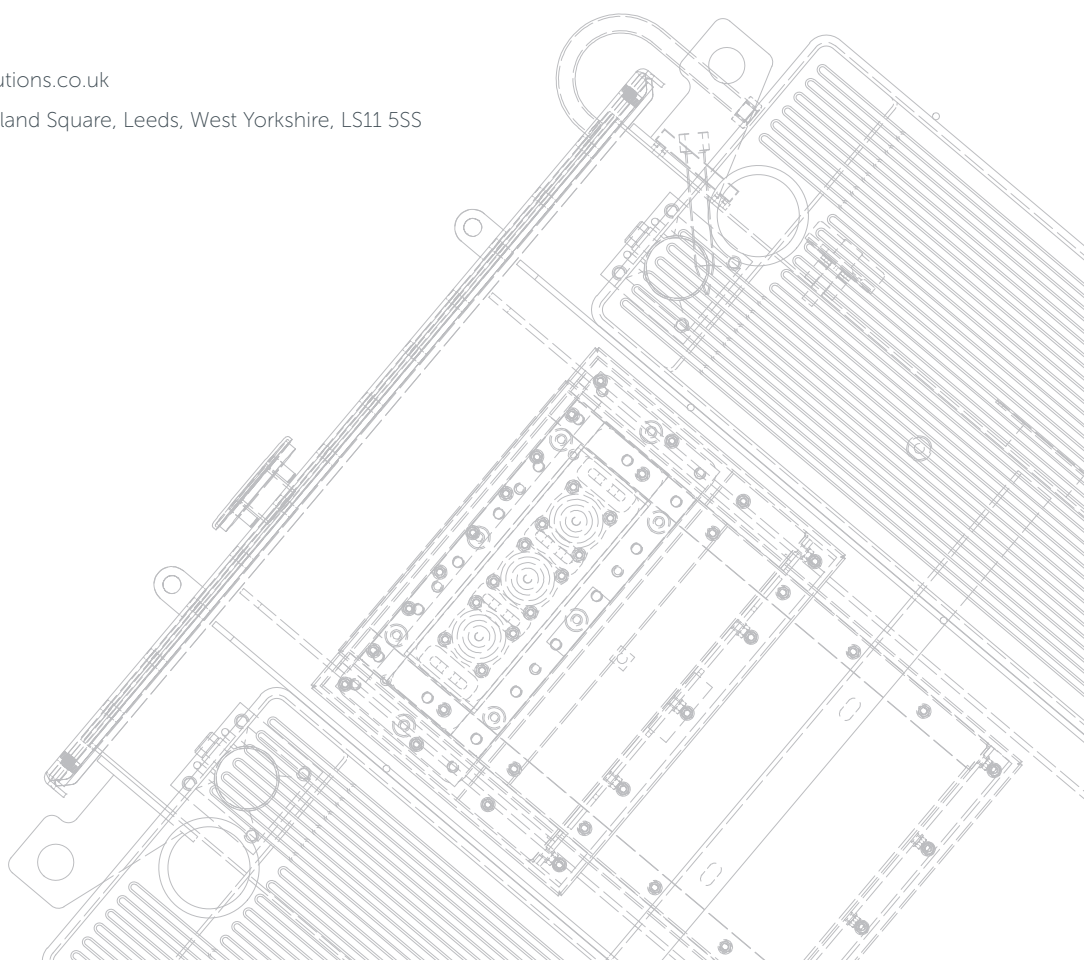

# OUR VISION

To be a family company with a conscience providing innovative, sustainable energy infrastructure solutions.

# OUR MISSION

We are committed to growing our business by continuing to deliver customer driven, tailored solutions and outstanding levels of service, whilst investing in the development of new and improved power distribution products and services.





## 8. ABOUT US

Wilson Power Solutions is based on a unique customer and professional approach that has been developed over 70 years in the industry.

Today, Wilson Power Solutions is managed by the third generation of the Wilson family who like their business to remain agile and friendly. Dedicated to helping customers find the best power distribution solutions for their individual needs, we are passionate about our expert knowledge and committed to giving advice with our customers' best interests at heart.

We treasure our heritage and know that our hard-earned reputation for service excellence and superior product performance has grown out of 70 years of experience in the power engineering sector.

### THE BEST SOLUTION FOR YOUR POWER NEEDS

Recognising the importance of integrity and reliability, we believe in building lasting partnerships with our customers that are based on a unique service based on technical knowledge, superior product performance and mutual trust.

//  
We believe in building lasting partnerships with our people, our customers, suppliers and our communities, both locally and internationally.

ERIKA WILSON MANAGING DIRECTOR

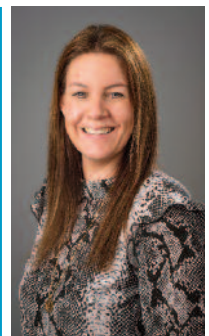

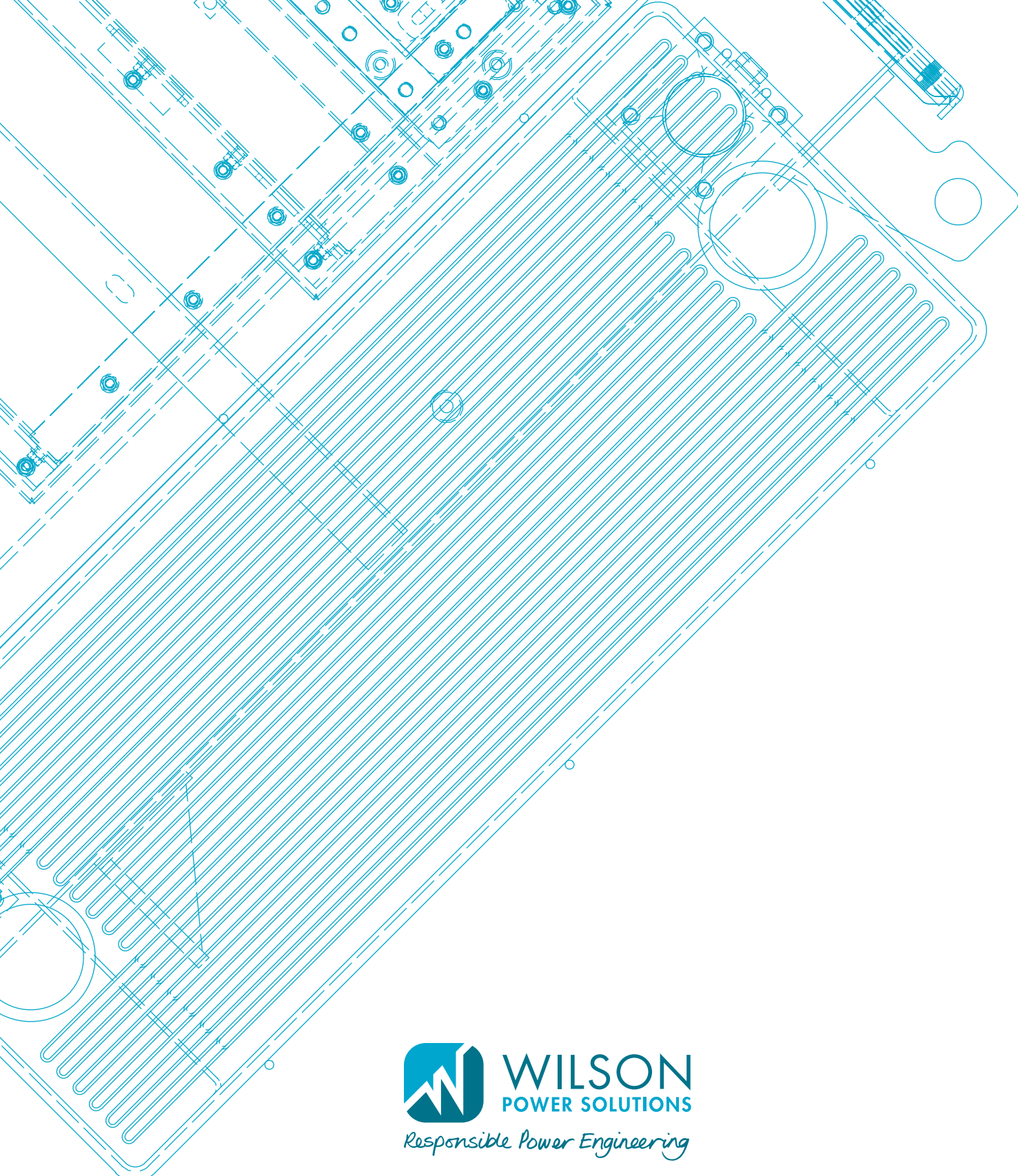

**Wilson Power Solutions Limited**  
Westland Works  
Westland Square  
Leeds LS11 5SS UK

T: +44 (0)113 271 7588  
E: [info@wilsonpowersolutions.co.uk](mailto:info@wilsonpowersolutions.co.uk)

001/102017