

TRANSFORMER WEIGHT & VOLUME		
CORE AND WINDING	kg	3415
TANK AND FITTING	kg	1125
COOLING LIQUID VOLUME	L	1445
COOLING LIQUID WEIGHT	kg	1180
TOTAL TX WEIGHT	kg	5720

1500kVA ELECTRICAL RATINGS					
No Load Voltage Ratio at Normal Tap	HV Tappings	Vector Group	Frequency	Full-Load Current at Normal Tap	
11000 / 415V	+7.5 to -5.0% in 2.5% INCREMENTS	Dyn11	50Hz	HV Side	LV Side
Design Impedance at Normal Tap	No Load Losses at rated Voltage & Frequency	Full Load Losses at rated Current & at 75°C Temp.	Temp. Rise above Ambient 40°C		
5.5%	560W	10156W	in Oil by Therm.	in Wdg. by Res.	
			60°C	65°C	

ITEM	QTY	DESCRIPTION
15	2	DETACHABLE RADIATORS with AIR-RELEASE & DRAIN PLUG (520W x 1200C x 55 x 40P)
14	1	DRAIN VALVE (25NB) with MALE PLUG
13	4	JACKING PADS
12	1	RATING & DIAGRAM PLATE (SS)
11	4	TRANSFORMER LIFTING LUGS
10	1	OFF-CIRCUIT TAP SWITCH (6-Position & Padlockable)
9	2	THERMOMETER POCKET (3/4" BSP MALE THREAD)
8	1	OIL FILLING PIPE WITH FLANGED COVER
7	1	TOP COVER with LIFTING LUGS (x2)
6	1	OIL LEVEL GAUGE (with 15°) COLD OIL LEVEL MARK
5	1	AIR VENT PIPE (3/4") FOR DEHYDRANT BREATHER
4	2	EARTHING TERMINAL (FLAT TYPE suitable for M12 Bolt)
3	1	TRANSFORMER BASE (SKID TYPE) c/w HAULAGE HOLES & BRACING
2	1	LV CABLE BOX - 1.1kV, 4-POLE, AIR INSULATION, (FACING-'F', BS:2562) SUITABLE FOR 3 x 1c CABLES PER PHASE & N - MAX. 630mm.sq
1	1	HV CABLE BOX - 12kV, 3-POLE, HEAT-SHRINK INSULATION, (FACING-'E' BS:2562) SUITABLE FOR 1 x 3c CABLE - MAX. 185mm.sq

ESSENTIAL LABELS

- ITEM 10 TAP CHANGER WARNING LABEL
- ITEM 6 COLD COOLANT LEVEL
- ITEM 2 LV WARNING LABEL
- ITEM 1 HV WARNING LABEL

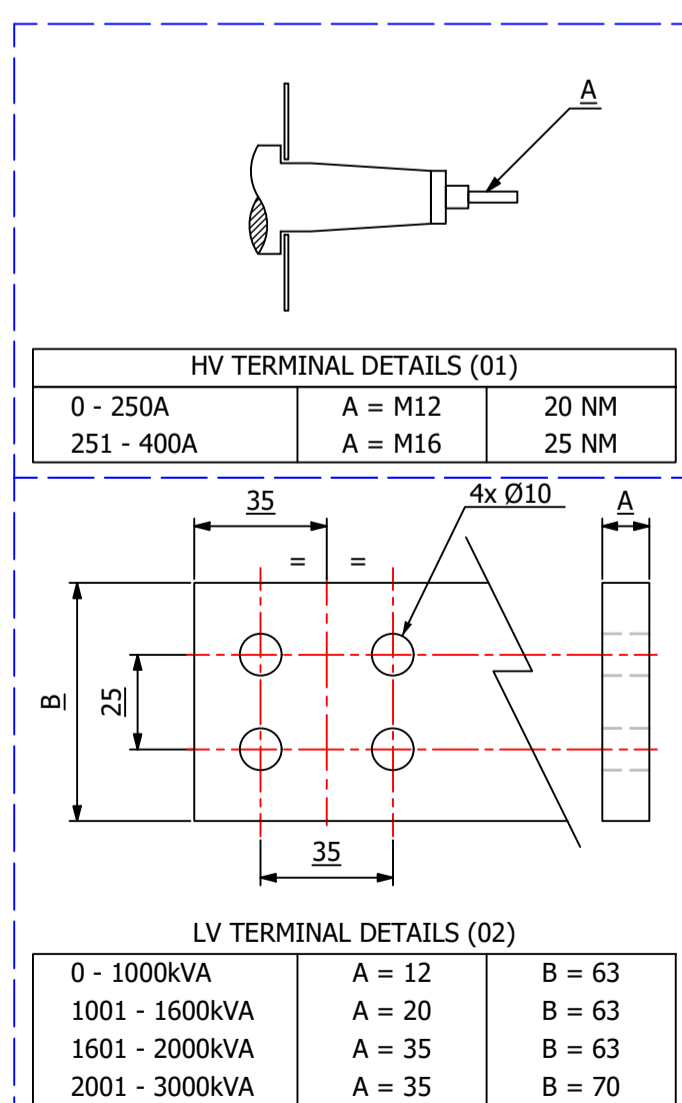

IF IN DOUBT - ASK. REMOVE ALL SHARP EDGES. DO NOT SCALE. DRAWING NOT TO SCALE

REV	REV BY	VERIFIED	APPROVED	DESCRIPTION

REVISION DESCRIPTION	REV	PROJECT
ORIGINAL	00	CUSTOMER
		S.O. NUMBER
		P.O. NUMBER
		W.O. NUMBER

DATE	PROJECT
10-OCT-2019	

DRAWING TITLE
GENERAL ARRANGEMENT DRAWING FOR 1500kVA WILSON e3 ECOTRANS ULTRA LOW LOSS 11000/415V, 50Hz, Dyn11, ONAN/KNAN AL WOUND DISTRIBUTION TRANSFORMER

**Wilson Power Solutions Ltd.**  
 Westland Square, Leeds,  
 West Yorkshire LS11 5SS, United Kingdom  
 Tel: +44 (0) 113 271 7588  
 Fax: +44 (0) 113 277 5124  
 web: www.wilsonpowersolutions.co.uk email: info@wilsonpowersolutions.co.uk

WILSON POWER SOLUTIONS

DRAWN BY: M.WRIGHT DATE: 10/10/2019 DRG NO: WPS-E3-1500-AL-GA