

TRANSFORMER WEIGHT & VOLUME		
CORE AND WINDING	kg	1700
TANK AND FITTING	kg	760
COOLING LIQUID VOLUME	L	1000
COOLING LIQUID WEIGHT	kg	815
TOTAL TX WEIGHT	kg	3275
ADDITIONS TO THE TRANSFORMER WEIGHT		
RN2d RMU WEIGHT	Kg	300

500kVA		ELECTRICAL RATINGS			
No Load Voltage Ratio at Normal Tap	HV Tappings	Vector Group	Frequency	Full-Load Current at Normal Tap	
				HV Side	LV Side
11000 / 415V	+7.5 to -5.0% in 2.5% INCREMENTS	Dyn11	50Hz	26.2A	695.6A
Design Impedance at Normal Tap	No Load Losses at rated Voltage & Frequency	Full Load Losses at rated Current & at 75°C Temp.	Temp. Rise above Ambient 40°C		
			in Oil by Therm.	in Wdg. by Res.	
4.75%	270W	3330W	60°C	65°C	

ESSENTIAL LABELS

- ITEM 10 TAP CHANGER WARNING LABEL
- ITEM 6 COLD COOLANT LEVEL - C.O.L. 15°C
- ITEM 2 LV WARNING LABEL
- ITEM 1 HV WARNING LABEL

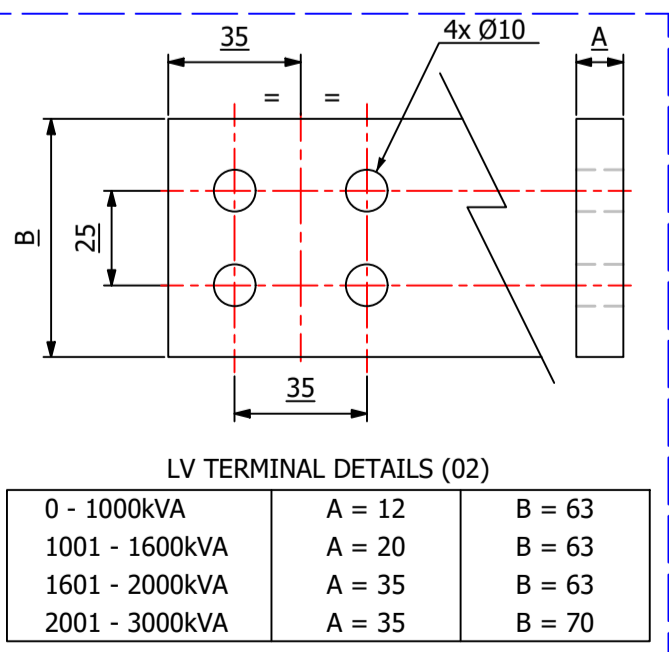

- GENERAL NOTES
- ALL DIMENSIONS ARE IN 'mm'.
  - ALL DIMENSIONS/WEIGHTS ARE SUBJECT TO ± 10% TOLERANCE.
  - ELECTRONIC SCALE - 1:1 (ONLY WRITTEN DIMENSIONS TO BE FOLLOWED).
  - TOLERANCE ON IMPEDANCE PER IEC:60076.
  - PAINT SHADE.: 632 AS PER BS:381C (SEMI GLOSS) TO ISO12944 - MIN C4 SPEC.
  - O/ALL DIM IS SUBJECT TO EQUIPMENT DOOR OPENING DISTANCES

ITEM	QTY	DESCRIPTION
14	1	DRAIN VALVE (25NB) with MALE PLUG
13	4	JACKING PADS
12	1	RATING & DIAGRAM PLATE (SS)
11	4	TRANSFORMER LIFTING LUGS
10	1	OFF-CIRCUIT TAP SWITCH (6-Position & Padlockable)
9	2	THERMOMETER POCKET (3/4" BSP MALE THREAD)
8	1	OIL FILLING PIPE WITH FLANGED COVER
7	1	TOP COVER with LIFTING LUGS (x2)
6	1	OIL LEVEL GAUGE (with 15°) COLD OIL LEVEL MARK
5	1	AIR VENT PIPE (3/4") FOR DEHYDRANT BREATHER
4	2	EARTHING TERMINAL (FLAT TYPE suitable for M12 Bolt)
3	1	TRANSFORMER BASE (SKID TYPE) c/w HAULAGE HOLES & BRACING
2	1	LV CABLE BOX - 1.1kV, 4-POLE, AIR INSULATION, (FACING-'F', BS:2562) SUITABLE FOR 1 x 1c CABLES PER PHASE & N - MAX. 630mm.sq
1	1	HV RMU - 11kV, 200A, GCB, 630A BUS [Schneider RN2d-Tx/21] x PROTECTION, (FACING-'E' BS:2526)

IF IN DOUBT - ASK. REMOVE ALL SHARP EDGES. DO NOT SCALE. DRAWING NOT TO SCALE

REV	REV BY	VERIFIED	APPROVED	DESCRIPTION

REVISION DESCRIPTION	REV	PROJECT
ORIGINAL	00	

CUSTOMER	S.O. NUMBER	P.O. NUMBER	W.O. NUMBER

**Wilson Power Solutions Ltd.**  
 Westland Square, Leeds,  
 West Yorkshire LS11 5SS, United Kingdom  
 Tel: +44 (0) 113 271 7588  
 Fax: +44 (0) 113 277 5124  
 web: www.wilsonpowersolutions.co.uk email: info@wilsonpowersolutions.co.uk

web: www.wilsonpowersolutions.co.uk email: info@wilsonpowersolutions.co.uk

DRAWN BY: M.WRIGHT DATE: 16/10/2019 DRG NO: **WPS-E3-500-AL-A001**