

TRANSFORMER WEIGHT & VOLUME		
CORE AND WINDING	kg	1700
TANK AND FITTING	kg	760
COOLING LIQUID VOLUME	L	1000
COOLING LIQUID WEIGHT	kg	815
TOTAL TX WEIGHT	kg	3275

500kVA		ELECTRICAL RATINGS			
No Load Voltage Ratio at Normal Tap	HV Tappings	Vector Group	Frequency	Full-Load Current at Normal Tap	
11000 / 415V	+7.5 to -5.0% in 2.5% INCREMENTS	Dyn11	50Hz	HV Side	LV Side
Design Impedance at Normal Tap	No Load Losses at rated Voltage & Frequency	Full Load Losses at rated Current & at 75°C Temp.	Temp. Rise above Ambient 40°C		
4.75%	270W	3330W	in Oil by Therm.	in Wdg. by Res.	
			60°C	65°C	

GENERAL NOTES			
1	ALL DIMENSIONS ARE IN 'mm'.		
2	ALL DIMENSIONS/WEIGHTS ARE SUBJECT TO ± 10% TOLERANCE.		
3	ELECTRONIC SCALE - 1:1 (ONLY WRITTEN DIMENSIONS TO BE FOLLOWED).		
4	TOLERANCE ON IMPEDANCE PER IEC:60076.		
5	PAINT SHADE.: 632 As PER BS:381C (SEMI GLOSS) TO ISO12944 - MIN C4 SPEC.		
6			
7			
8			
9			

**ESSENTIAL LABELS**

- ITEM 10: TAP CHANGER WARNING LABEL (OFF-CIRCUIT TAP CHANGER, NO OPEN CIRCUIT TAP)
- ITEM 6: COLD COOLANT LEVEL (-C.O.L. 15°C)
- ITEM 2: LV WARNING LABEL
- ITEM 1: HV WARNING LABEL

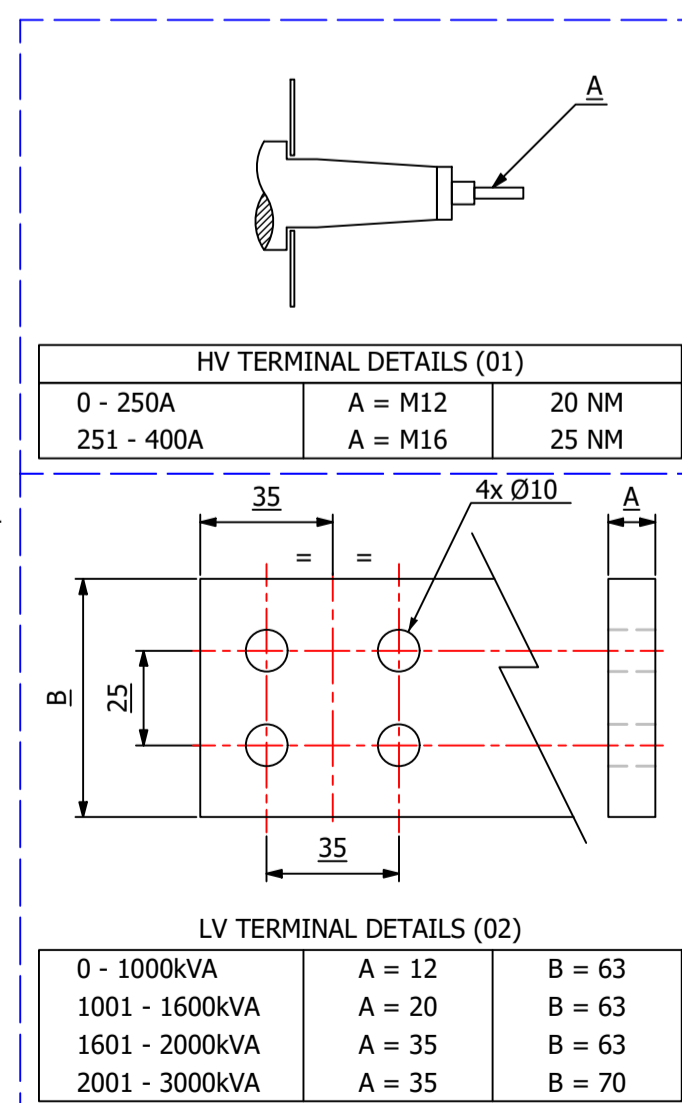

ITEM	QTY	DESCRIPTION
14	1	DRAIN VALVE (25NB) with MALE PLUG
13	4	JACKING PADS
12	1	RATING & DIAGRAM PLATE (SS)
11	4	TRANSFORMER LIFTING LUGS
10	1	OFF-CIRCUIT TAP SWITCH (6-Position & Padlockable)
9	2	THERMOMETER POCKET (3/4" BSP MALE THREAD)
8	1	OIL FILLING PIPE WITH FLANGED COVER
7	1	TOP COVER with LIFTING LUGS (x2)
6	1	OIL LEVEL GAUGE (with 15°) COLD OIL LEVEL MARK
5	1	AIR VENT PIPE (3/4") FOR DEHYDRANT BREATHER
4	2	EARTHING TERMINAL (FLAT TYPE suitable for M12 Bolt)
3	1	TRANSFORMER BASE (SKID TYPE) c/w HAULAGE HOLES & BRACING
2	1	LV CABLE BOX - 1.1kV, 4-POLE, AIR INSULATION, (FACING-'F', BS:2562) SUITABLE FOR 1 x 1c CABLES PER PHASE & N - MAX. 630mm.sq
1	1	HV CABLE BOX - 12kV, 3-POLE, HEAT-SHRINK INSULATION, (FACING-'E' BS:2562) SUITABLE FOR 1 x 3c CABLE - MAX. 185mm.sq

IF IN DOUBT - ASK. REMOVE ALL SHARP EDGES. DO NOT SCALE. DRAWING NOT TO SCALE

REV	REV BY	VERIFIED	APPROVED	DESCRIPTION

REVISION DESCRIPTION	REV	PROJECT
ORIGINAL	00	CUSTOMER
		S.O. NUMBER
		P.O. NUMBER
		W.O. NUMBER

DATE	PROJECT	DRAWING TITLE
08-JAN-2020		GENERAL ARRANGEMENT DRAWING FOR 500kVA WILSON e3 ECOTRANS ULTRA LOW LOSS 11000/415V, 50Hz, Dyn11, ONAN/KNAN AL WOUND DISTRIBUTION TRANSFORMER

DRAWN BY:	DATE:	DRG NO:
S. MALLETT	08/01/2020	WPS-E3-500-AL-GA

**Wilson Power Solutions Ltd.**  
 Westland Square, Leeds,  
 West Yorkshire LS11 5SS, United Kingdom  
 Tel: +44 (0) 113 271 7588  
 Fax: +44 (0) 113 277 5124  
 web: www.wilsonpowersolutions.co.uk email: info@wilsonpowersolutions.co.uk