

TRANSFORMER WEIGHT & VOLUME		
CORE AND WINDING	kg	2270
TANK AND FITTING	kg	890
COOLING LIQUID VOLUME	L	1300
COOLING LIQUID WEIGHT	kg	1060
TOTAL TX WEIGHT	kg	4220

800kVA ELECTRICAL RATINGS					
No Load Voltage Ratio at Normal Tap	HV Tappings	Vector Group	Frequency	Full-Load Current at Normal Tap	
				HV Side	LV Side
11000 / 415V	+7.5 to -5.0% in 2.5% INCREMENTS	Dyn11	50Hz	41.9A	1112.9A
Design Impedance at Normal Tap	No Load Losses at rated Voltage & Frequency	Full Load Losses at rated Current & at 75°C Temp.	Temp. Rise above Ambient 40°C		
			in Oil by Therm.	in Wdg. by Res.	
4.75%	380W	5160W	60°C	65°C	

ITEM	QTY	DESCRIPTION
14	1	DRAIN VALVE (25NB) with MALE PLUG
13	4	JACKING PADS
12	1	RATING & DIAGRAM PLATE (SS)
11	4	TRANSFORMER LIFTING LUGS
10	1	OFF-CIRCUIT TAP SWITCH (6-Position & Padlockable)
9	2	THERMOMETER POCKET (3/4" BSP MALE THREAD)
8	1	OIL FILLING PIPE WITH FLANGED COVER
7	1	TOP COVER with LIFTING LUGS (x2)
6	1	OIL LEVEL GAUGE (with 15°) COLD OIL LEVEL MARK
5	1	AIR VENT PIPE (3/4") FOR DEHYDRANT BREATHER
4	2	EARTHING TERMINAL (FLAT TYPE suitable for M12 Bolt)
3	1	TRANSFORMER BASE (SKID TYPE) c/w HAULAGE HOLES & BRACING
2	1	LV CABLE BOX - 1.1kV, 4-POLE, AIR INSULATION, (FACING-'F', BS:2562) SUITABLE FOR 2 x 1c CABLES PER PHASE & N - MAX. 630mm.sq
1	1	HV CABLE BOX - 12kV, 3-POLE, HEAT-SHRINK INSULATION, (FACING-'E' BS:2562) SUITABLE FOR 1 x 3c CABLE - MAX. 185mm.sq

ESSENTIAL LABELS

- ITEM 10: TAP CHANGER WARNING LABEL
- ITEM 6: COLD COOLANT LEVEL (-C.O.L. 15°C)
- ITEM 2: LV WARNING LABEL
- ITEM 1: HV WARNING LABEL

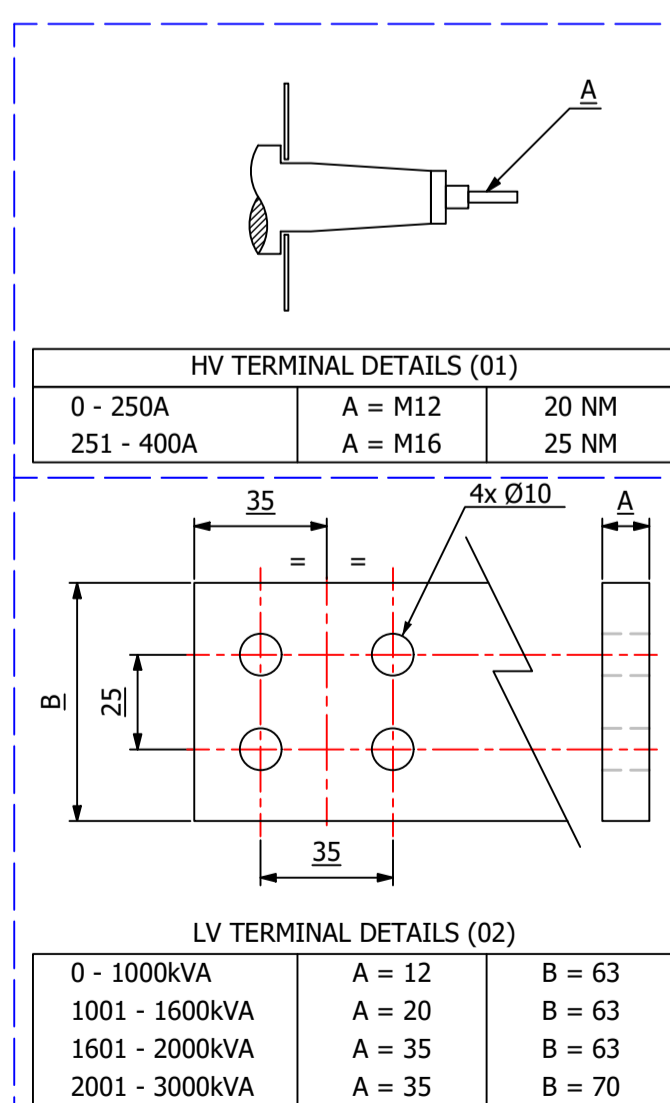

IF IN DOUBT - ASK. REMOVE ALL SHARP EDGES. DO NOT SCALE. DRAWING NOT TO SCALE

REV	REV BY	VERIFIED	APPROVED	DESCRIPTION

REVISION DESCRIPTION	REV	PROJECT
ORIGINAL	00	CUSTOMER

DATE	P.O. NUMBER	W.O. NUMBER
10-OCT-2019		

DRAWING TITLE	
GENERAL ARRANGEMENT DRAWING FOR 800kVA WILSON e3 ECOTRANS ULTRA LOW LOSS 11000/415V, 50Hz, Dyn11, ONAN/KNAN AL WOUND DISTRIBUTION TRANSFORMER	

Wilson Power Solutions Ltd.
 Westland Square, Leeds,
 West Yorkshire LS11 5SS, United Kingdom
 Tel: +44 (0) 113 271 7588
 Fax: +44 (0) 113 277 5124
 web: www.wilsonpowersolutions.co.uk email: info@wilsonpowersolutions.co.uk

WILSON POWER SOLUTIONS

web: www.wilsonpowersolutions.co.uk email: info@wilsonpowersolutions.co.uk

DRAWN BY: M.WRIGHT DATE: 10/10/2019 DRG NO: WPS-E3-800-AL-GA