

GENERIC LV CABINET SHOWN. SIZES MAY CHANGE. FINAL DESIGN MAY REQUIRE SEPARATION FROM THE TX FOR TRANSPORTATION.

ESSENTIAL LABELS

- ITEM 10 TAP CHANGER WARNING LABEL
- ITEM 6 COLD COOLANT LEVEL
- ITEM 2 LV WARNING LABEL
- ITEM 1 HV WARNING LABEL

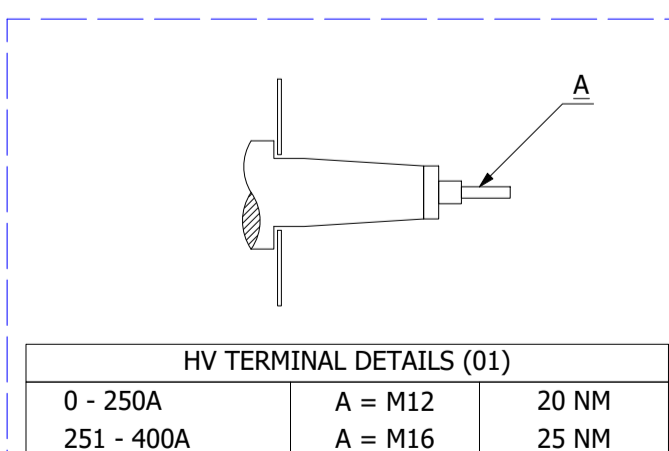

TRANSFORMER WEIGHT & VOLUME		
CORE AND WINDING	kg	2545
TANK AND FITTING	kg	1020
COOLING LIQUID VOLUME	L	900
COOLING LIQUID WEIGHT	kg	735
TOTAL TX WEIGHT	kg	4300
ADDITIONS TO THE TRANSFORMER WEIGHT		
LV CABINET	Kg	---

1500kVA ELECTRICAL RATINGS					
No Load Voltage Ratio at Normal Tap	HV Tappings	Vector Group	Frequency	Full-Load Current at Normal Tap	
				HV Side	LV Side
11000 / 433V	+5.0 to -5.0% in 2.5% INCREMENTS	Dyn11	50Hz	78.730A	2000.059A
Design Impedance at Normal Tap	No Load Losses at rated Voltage & Frequency	Full Load Losses at rated Current & at 75°C Temp.	Temp. Rise above Ambient 40°C		
			in Oil by Therm.	in Wdg. by Res.	
5.5%	1015W	11285W	60°C	65°C	

GENERAL NOTES

- ALL DIMENSIONS ARE IN 'mm'.
- ALL DIMENSIONS/WEIGHTS ARE SUBJECT TO ± 10% TOLERANCE.
- ELECTRONIC SCALE - 1:1 (ONLY WRITTEN DIMENSIONS TO BE FOLLOWED).
- TOLERANCE ON IMPEDANCE PER IEC:60076.
- PAINT SHADE.: 632 AS PER BS:381C (SEMI GLOSS) TO ISO12944 - MIN C4 SPEC.
- O/ALL DIM IS SUBJECT TO EQUIPMENT DOOR OPENING DISTANCES.

ITEM	QTY	DESCRIPTION
15	4	DETACHABLE RADIATORS with AIR-RELEASE & DRAIN PLUG (520W x 1200C x 55 x 40P)
14	1	DRAIN VALVE (25NB) with MALE PLUG
13	4	JACKING PADS
12	1	RATING & DIAGRAM PLATE (SS)
11	2	TRANSFORMER LIFTING LUGS
10	1	OFF-CIRCUIT TAP SWITCH (5-Position & Padlockable)
9	2	THERMOMETER POCKET (3/4" BSP MALE THREAD)
8	1	OIL FILLING PIPE WITH FLANGED COVER
7	1	TOP COVER with LIFTING LUGS (x2)
6	1	OIL LEVEL GAUGE (with 15°) COLD OIL LEVEL MARK
5	1	AIR VENT PIPE (3/4") FOR DEHYDRANT BREATHER
4	2	EARTHING TERMINAL (FLAT TYPE suitable for M12 Bolt)
3	1	TRANSFORMER BASE (SKID TYPE) c/w HAULAGE HOLES & BRACING
2	1	LV CABINET, BOTTOM ENTRY, GENERIC MODEL - SUBJECT TO CHANGE (FACING-'F', BS:2562)
1	1	HV CABLE BOX - 12kV, 3-POLE, HEAT-SHRINK INSULATION, (FACING-'E' BS:2562) SUITABLE FOR 1 x 3c CABLE - MAX. 185mm.sq

IF IN DOUBT - ASK. REMOVE ALL SHARP EDGES. DO NOT SCALE. DRAWING NOT TO SCALE

REV	REV BY	VERIFIED	APPROVED	DESCRIPTION

REVISION DESCRIPTION	REV	PROJECT
ORIGINAL	00	CUSTOMER
		S.O. NUMBER
		P.O. NUMBER
		W.O. NUMBER

DRAWING TITLE
GENERAL ARRANGEMENT DRAWING FOR 1500kVA WILSON T2 ECOTRANS 11000/433V, 50Hz, Dyn11, ONAN/KNAN AL WOUND DISTRIBUTION TRANSFORMER LV CABINET

Wilson Power Solutions Ltd.
 Westland Square, Leeds,
 West Yorkshire LS11 5SS, United Kingdom
 Tel: +44 (0) 113 271 7588
 Fax: +44 (0) 113 277 5124
 web: www.wilsonpowersolutions.co.uk email: info@wilsonpowersolutions.co.uk

DRAWN BY: M. STOTSJUK DATE: 07/04/2021 DRG NO: **WPS-T2-1500-AL-A003**