

PLAN VIEW

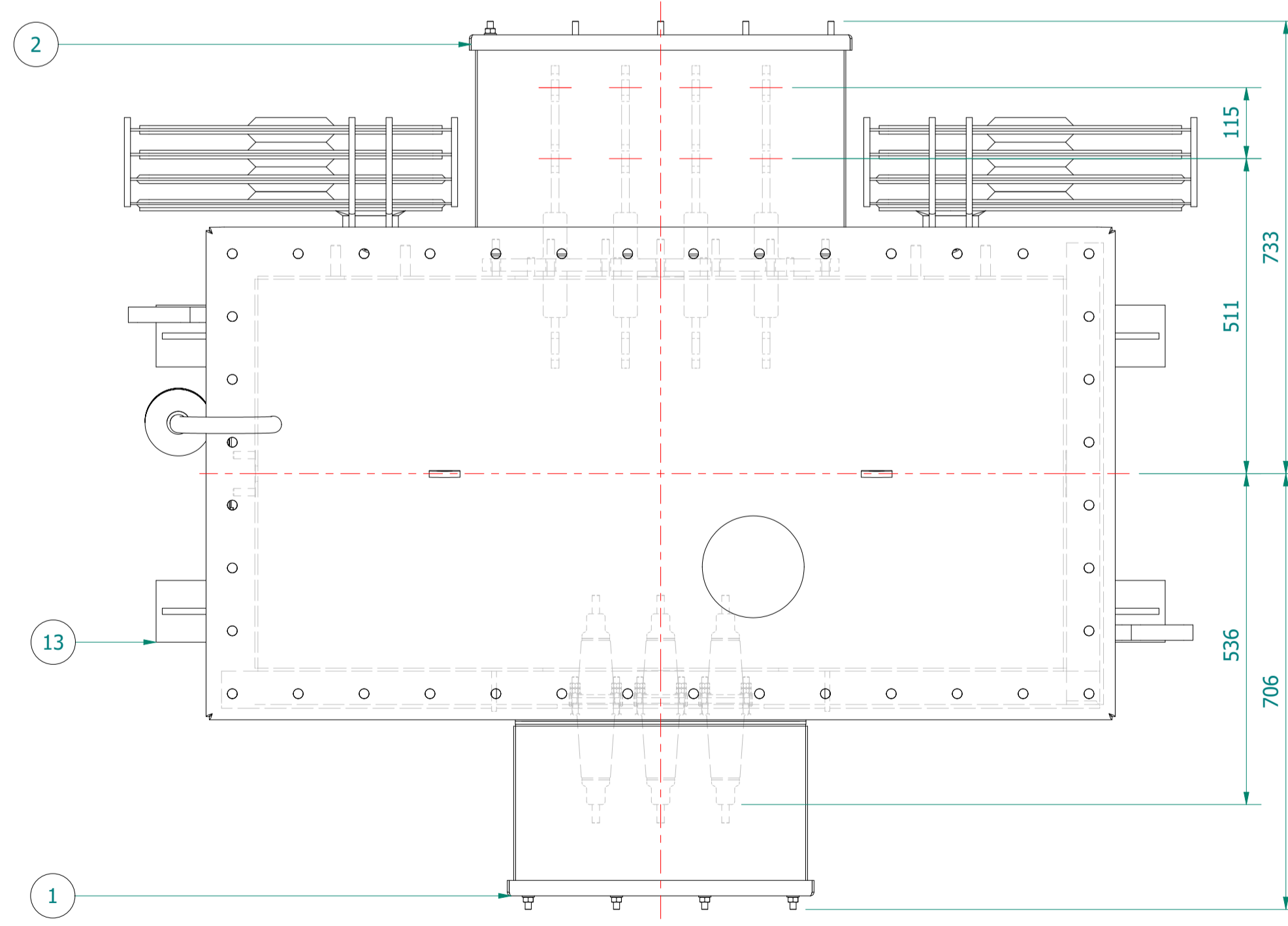

WILSON
T² ECOTRANS

TRANSFORMER WEIGHT & VOLUME		
CORE AND WINDING	kg	1900
TANK AND FITTING	kg	850
COOLING LIQUID VOLUME	L	800
COOLING LIQUID WEIGHT	kg	650
TOTAL TX WEIGHT	kg	3400

800kVA ELECTRICAL RATINGS					
No Load Voltage Ratio at Normal Tap	HV Tappings	Vector Group	Frequency	Full-Load Current at Normal Tap	
11000 / 433V	+5.0 to -5.0% in 2.5% INCREMENTS	Dyn11	50Hz	HV Side	LV Side
Design Impedance at Normal Tap	No Load Losses at rated Voltage & Frequency	Full Load Losses at rated Current & at 75°C Temp.	Temp. Rise above Ambient 40°C		
4.75%	585W	6000W	60°C	in Oil by Therm. in Wdg. by Res.	
65°C					

- GENERAL NOTES**
- ALL DIMENSIONS ARE IN 'mm'.
 - ALL DIMENSIONS/WEIGHTS ARE SUBJECT TO ± 10% TOLERANCE.
 - ELECTRONIC SCALE - 1:1 (ONLY WRITTEN DIMENSIONS TO BE FOLLOWED).
 - TOLERANCE ON IMPEDANCE PER IEC:60076.
 - PAINT SHADE.: 632 AS PER BS:381C (SEMI GLOSS) TO ISO12944 - MIN C4 SPEC.

ESSENTIAL LABELS

- ITEM 10 OFF-CIRCUIT TAP CHANGER WARNING LABEL
- ITEM 6 C.O.L. 15°C COLD COOLANT LEVEL
- ITEM 2 LV WARNING LABEL
- ITEM 1 HV WARNING LABEL

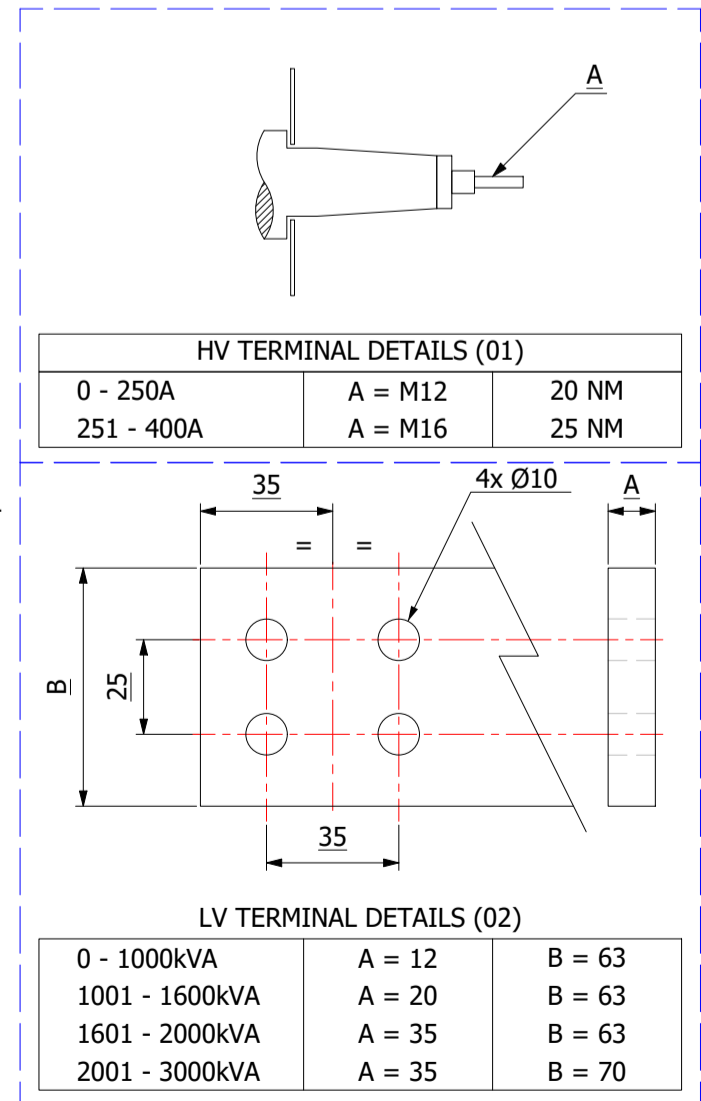

ITEM	QTY	DESCRIPTION
15	2	DETACHABLE RADIATORS with AIR-RELEASE & DRAIN PLUG (520W x 1200C x 45 x 40P)
14	1	DRAIN VALVE (25NB) with MALE PLUG
13	4	JACKING PADS
12	1	RATING & DIAGRAM PLATE BRACKET
11	2	TRANSFORMER LIFTING LUGS
10	1	OFF-CIRCUIT TAP SWITCH (5-Position & Padlockable)
9	2	THERMOMETER POCKET (3/4" BSP MALE THREAD)
8	1	OIL FILLING PIPE WITH FLANGED COVER
7	1	TOP COVER with LIFTING LUGS (x2)
6	1	OIL LEVEL GAUGE (with 15°) COLD OIL LEVEL MARK
5	1	AIR VENT PIPE (3/4") FOR DEHYDRANT BREATHER
4	2	EARTHING TERMINAL (FLAT TYPE suitable for M12 Bolt)
3	1	TRANSFORMER BASE (SKID TYPE) c/w HAULAGE HOLES & BRACING
2	1	LV CABLE BOX - 1.1kV, 4-POLE, AIR INSULATION, (FACING-'F', BS:2562) SUITABLE FOR 2 x 1c CABLES PER PHASE & N - MAX. 630mm.sq
1	1	HV CABLE BOX - 12kV, 3-POLE, HEAT-SHRINK INSULATION, (FACING-'E' BS:2562) SUITABLE FOR 1 x 3c CABLE - MAX. 185mm.sq

IF IN DOUBT - ASK. REMOVE ALL SHARP EDGES. DO NOT SCALE. DRAWING NOT TO SCALE

REV	REV BY	VERIFIED	APPROVED	DESCRIPTION

REVISION DESCRIPTION	REV	PROJECT
ORIGINAL	00	CUSTOMER
		S.O. NUMBER
		P.O. NUMBER
		W.O. NUMBER

REV	DATE
00	25-JAN-2021

DRAWING TITLE
GENERAL ARRANGEMENT DRAWING FOR 800kVA WILSON T2 ECOTRANS 11000/433V, 50Hz, Dyn11, ONAN/KNAN AL WOUND DISTRIBUTION TRANSFORMER

Wilson Power Solutions Ltd.
Westland Square, Leeds,
West Yorkshire LS11 5SS, United Kingdom
Tel: +44 (0) 113 271 7588
Fax: +44 (0) 113 277 5124
web: www.wilsonpowersolutions.co.uk email: info@wilsonpowersolutions.co.uk

DRAWN BY: S. MALLETT DATE: 25/02/2021 DRG NO: **WPS-T2-800-AL-GA**