

PLAN VIEW

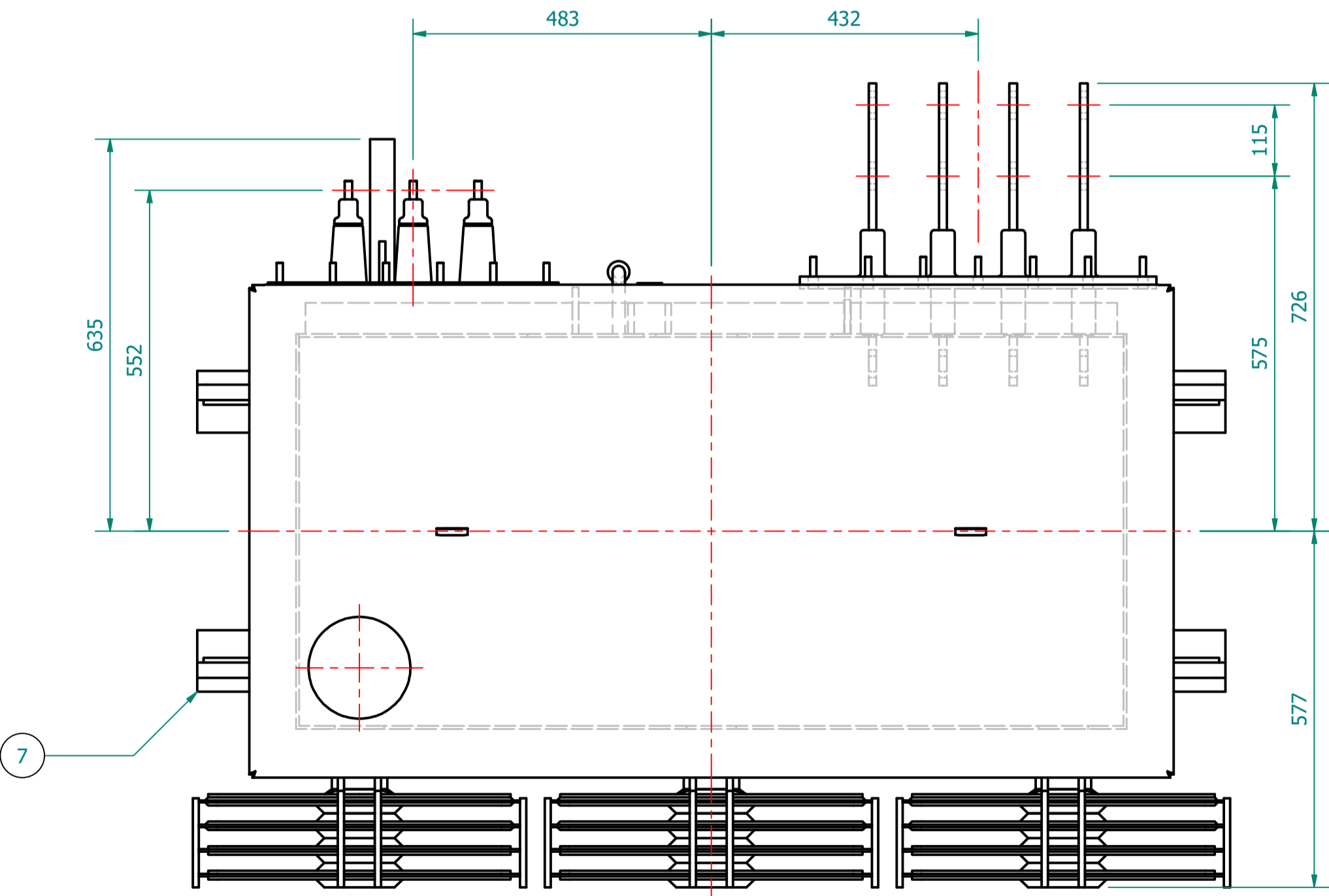

TRANSFORMER WEIGHT & VOLUME		
CORE AND WINDING	kg	1790
TANK AND FITTING	kg	1160
COOLING LIQUID VOLUME	L	854
COOLING LIQUID WEIGHT	kg	700
TOTAL TX WEIGHT	kg	3650

ESSENTIAL LABELS

- ITEM 7: OFF-CIRCUIT TAP CHANGERS / SO NEVER OPERATE (TOP) TAP CHANGER WARNING LABEL
- ITEM 4: C.O.L. 15°C COLD COOLANT LEVEL
- LV WARNING LABEL
- HV WARNING LABEL

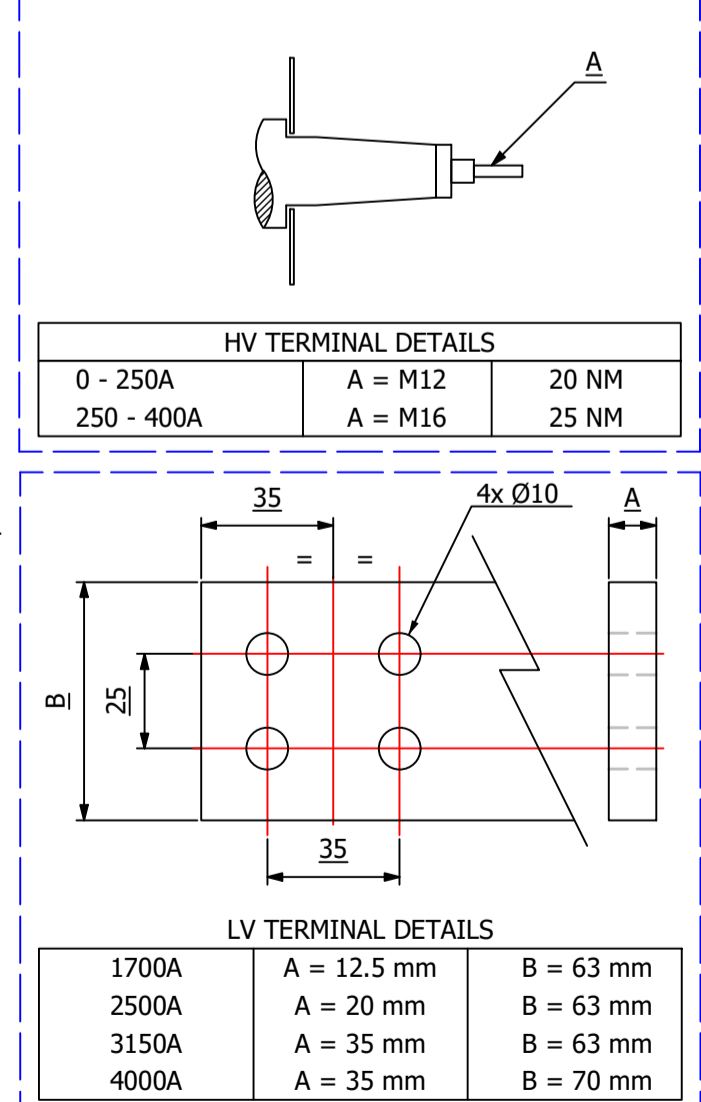

1000kVA ELECTRICAL RATINGS					
No Load Voltage Ratio at Normal Tap	HV Tappings	Vector Group	Frequency	Full-Load Current at Normal Tap	
				HV Side	LV Side
11000 / 433V	+5 to -5.0% in 2.5% INCREMENTS	Dyn11	50Hz	52.49A	1333.37A
Design Impedance at Normal Tap	No Load Losses at rated Voltage & Frequency	Full Load Losses at rated Current & at 75°C Temp.	Temp. Rise above Ambient 40°C		
			in Oil by Therm.	in Wdg. by Res.	
4.75%	693W	7600W	60°C	65°C	

GENERAL NOTES

- ALL DIMENSIONS ARE IN 'mm'.
- ALL DIMENSIONS/WEIGHTS ARE SUBJECT TO ± 10% TOLERANCE.
- ELECTRONIC SCALE - 1:1 (ONLY WRITTEN DIMENSIONS TO BE FOLLOWED).
- TOLERANCE ON IMPEDANCE PER IEC:60076.
- PAINT SHADE.: 632 As PER BS:381C (SEMI GLOSS) TO ISO12944 - MIN C4 SPEC.

ITEM	QTY	DESCRIPTION
11	3	DETACHABLE RADIATORS with AIR-RELEASE & DRAIN PLUG (520W x 1200C x 4S x 40P)
10	1	TRANSFORMER BASE (SKID TYPE) c/w HAULAGE HOLES
9	4	TRANSFORMER LIFTING LUGS
8	1	DRAIN VALVE (25NB) with MALE PLUG
7	4	JACKING PADS
6	1	RATING & DIAGRAM PLATE (SS)
5	1	DE-ENERGIZE TAP CHANGER (5-Position & Padlockable)
4	1	EARTHING TERMINAL (FLAT TYPE suitable for M12 Bolt)
3	1	TOP COVER with LIFTING LUGS (x2)
2	1	OIL FILLING PIPE WITH FLANGED COVER
1	1	OIL LEVEL GAUGE (with 15°) COLD OIL LEVEL MARK

IF IN DOUBT - ASK. REMOVE ALL SHARP EDGES. DO NOT SCALE. DRAWING NOT TO SCALE.

MANUFACTURED BY: **TOSHIBA TRANSFORMER**
TOSHIBA TRANSMISSION & DISTRIBUTION SYSTEMS (INDIA) PVT. LTD.

REV	REV BY	VERIFIED	APPROVED	DESCRIPTION

REVISION DESCRIPTION	REV	PROJECT
ORIGINAL	00	

REV. BY:	DATE	CUSTOMER
J. NOVO	14-OCT-2022	

S.O. NUMBER	P.O. NUMBER	W.O. NUMBER

DRAWING TITLE
GENERAL ARRANGEMENT DRAWING FOR d2, 1000kVA 11000/433V, 50Hz, Dyn11, ONAN AL WOUND UNIT TYPE TRANSFORMER

SUPPLIED BY: **Wilson Power Solutions Ltd.**
Westland Square, Leeds, West Yorkshire LS11 5SS, United Kingdom
Tel: +44 (0) 113 271 7588 Fax: +44 (0) 113 277 5124
web: www.wilsonpowersolutions.co.uk email: info@wilsonpowersolutions.co.uk

web: www.wilsonpowersolutions.co.uk email: info@wilsonpowersolutions.co.uk

DRAWN BY: J. NOVO DATE: 14/10/2022 DRG NO: WPS-d2-SPEN-1000-AL-U001