

VIEW ON HV SIDE
PHASE ROTATION
1U 1V 1W

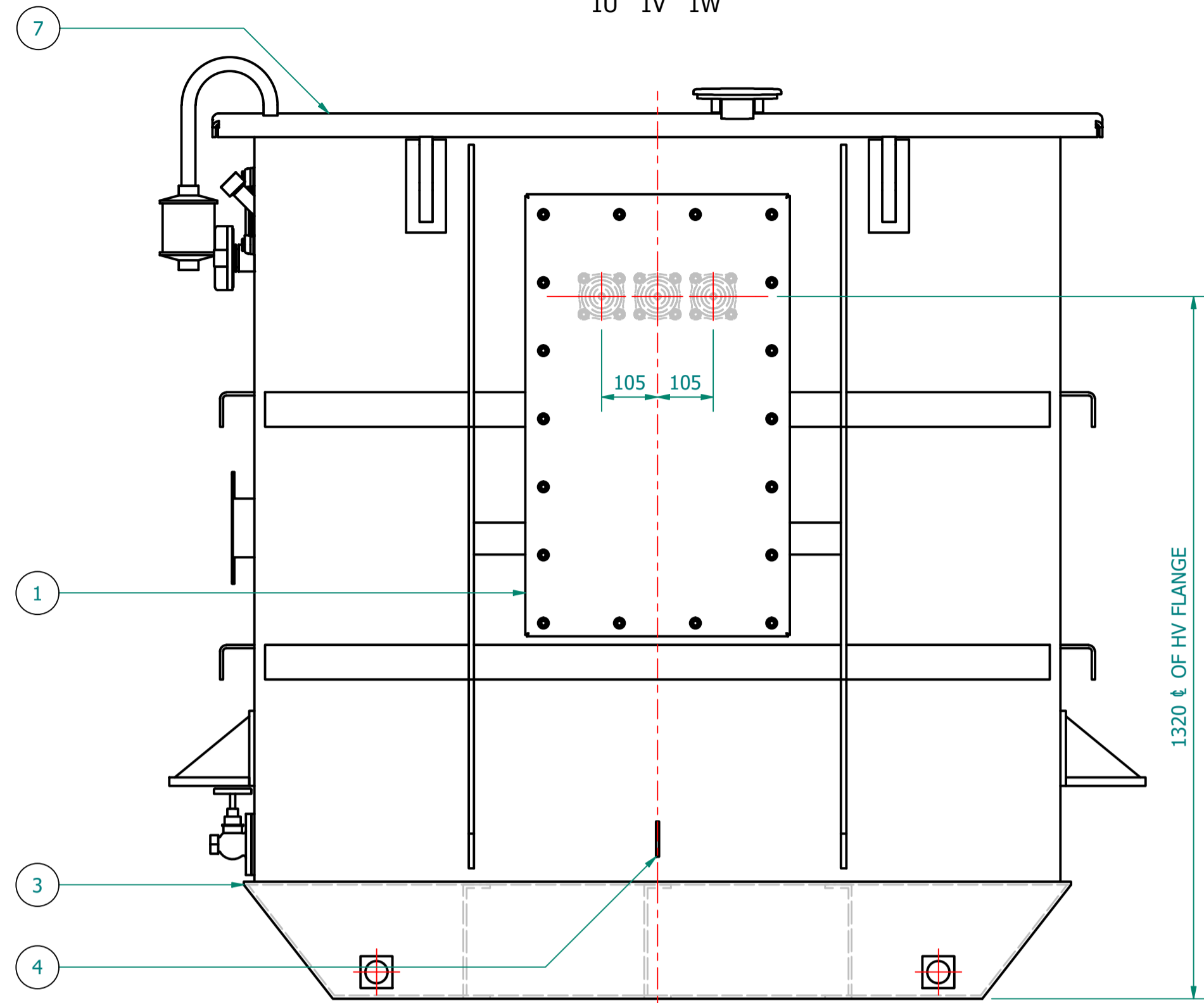

VIEW ON TAP SWITCH END

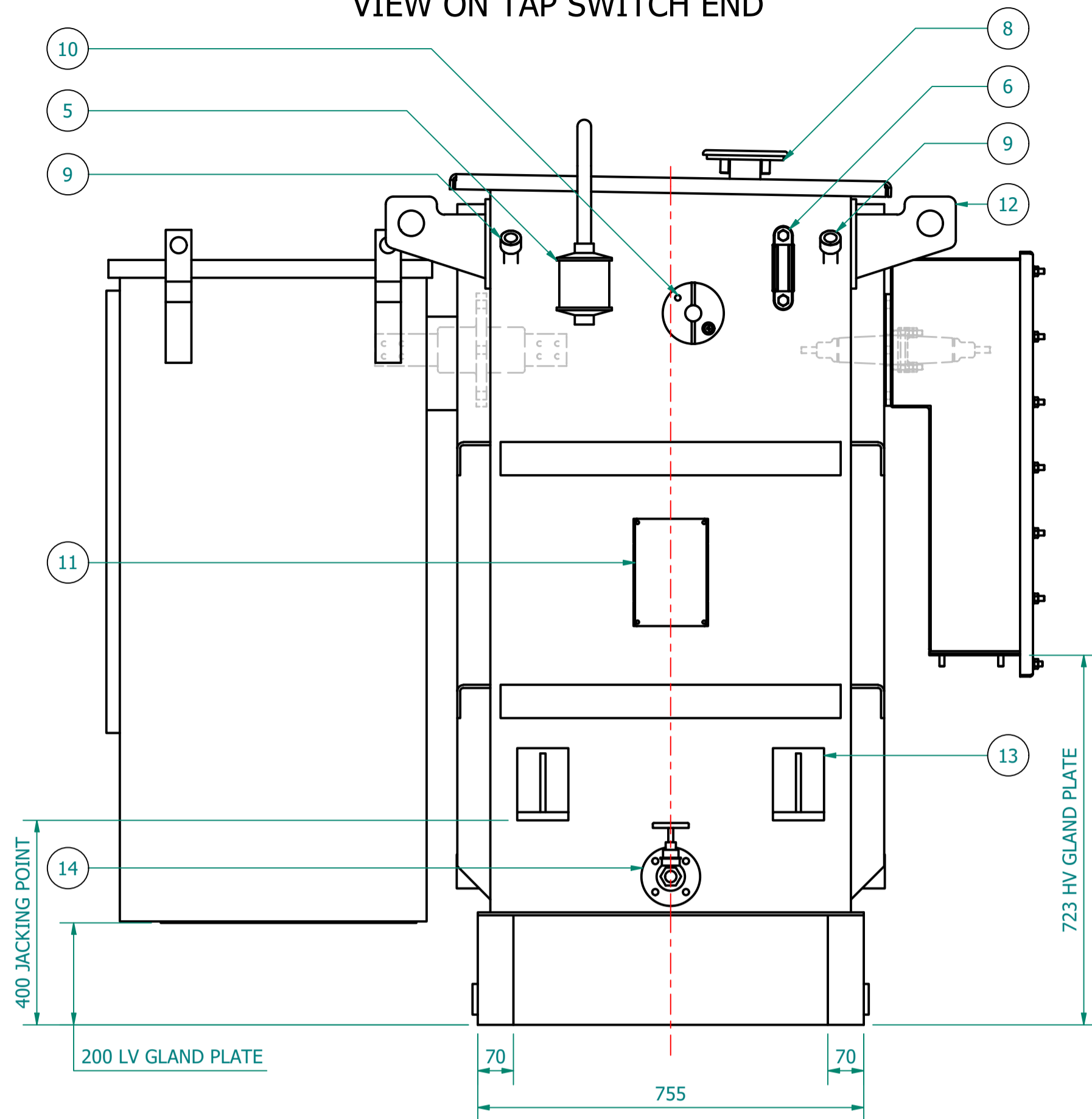

VIEW ON LV SIDE
PHASE ROTATION
2W 2V 2U 2N

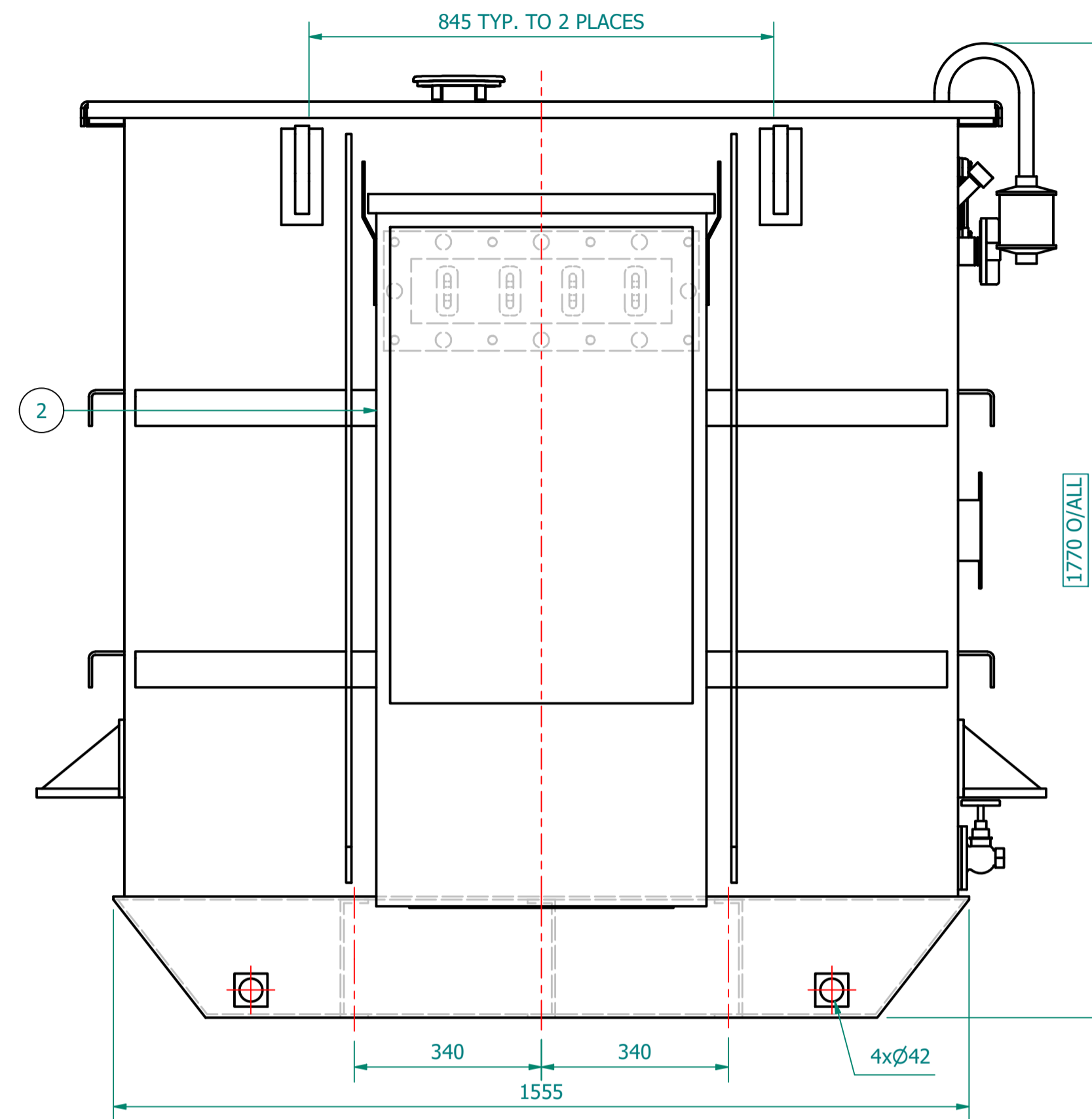

PLAN VIEW

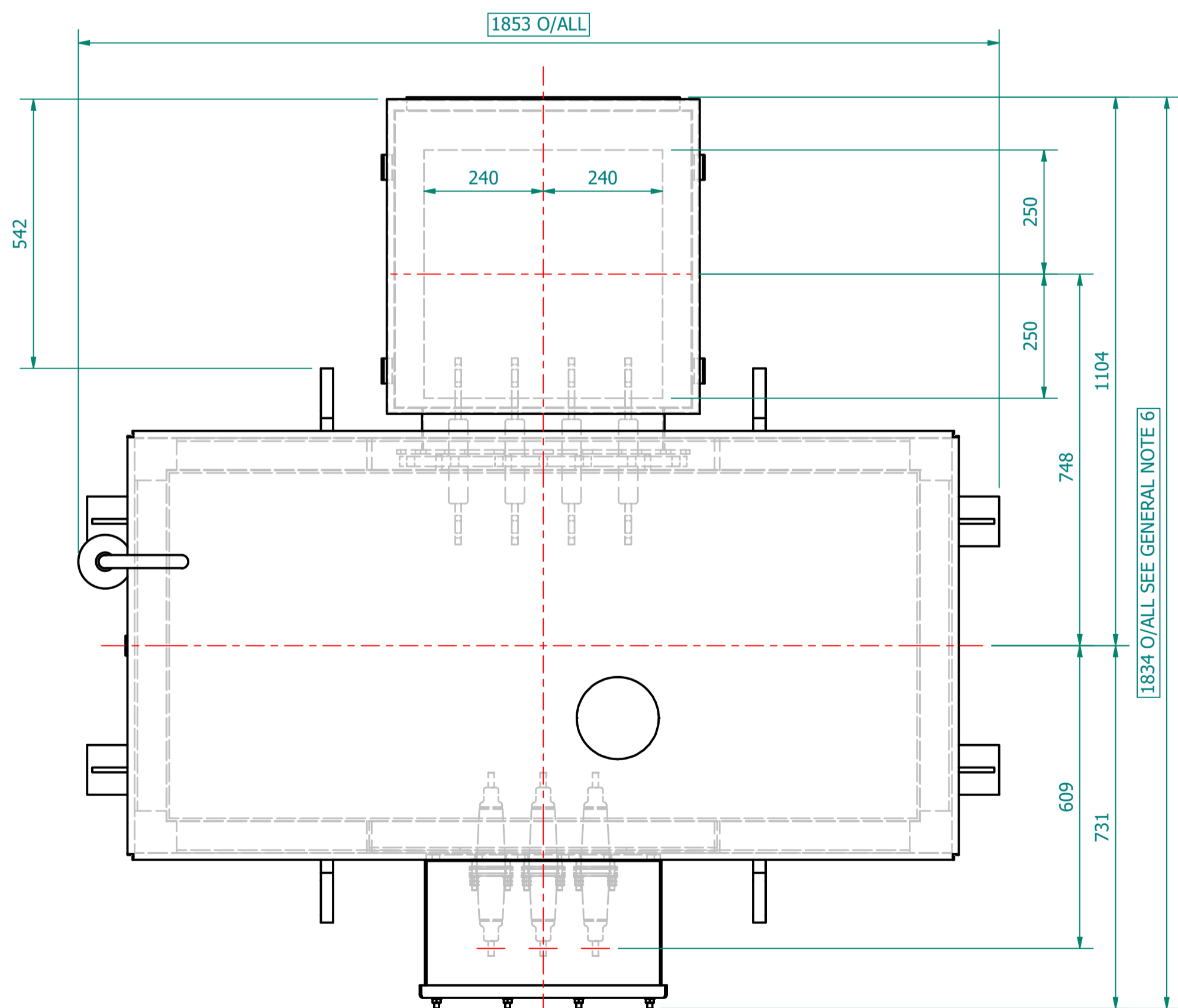

GENERIC LV CABINET SHOWN.
SIZES MAY CHANGE.
FINAL DESIGN MAY REQUIRE SEPARATION
FROM THE TX FOR TRANSPORTATION.



TRANSFORMER WEIGHT & VOLUME		
CORE AND WINDING	kg	1360
TANK AND FITTING	kg	690
COOLING LIQUID VOLUME	L	1044
COOLING LIQUID WEIGHT	kg	850
TOTAL TX WEIGHT	kg	2900
ADDITIONS TO THE TRANSFORMER WEIGHT		
LV CABINET	Kg	---

315kVA ELECTRICAL RATINGS					
No Load Voltage Ratio at Normal Tap	HV Tappings	Vector Group	Frequency	Full-Load Current at Normal Tap	
				HV Side	LV Side
11000 / 415V	+7.5 to -5.0% IN 2.5% INCREMENTS	Dyn11	50Hz	16.533A	438.23A
Design Impedance at Normal Tap	No Load Losses at rated Voltage & Frequency	Full Load Losses at rated Current & at 75°C Temp.	Temp. Rise above Ambient 40°C		
			in Oil by Therm.		in Wdg. by Res.
4.75%	215W	1940W	60°C	65°C	

ITEM	QTY	DESCRIPTION
14	1	DRAIN VALVE (25NB) WITH MALE PLUG
13	4	JACKING PADS
12	4	TRANSFORMER LIFTING LUGS
11	1	RATING & DIAGRAM PLATE (SS)
10	1	OFF-CIRCUIT TAP SWITCH (6-Position & Padlockable)
9	2	THERMOMETER POCKET (3/4" BSP MALE THREAD)
8	1	OIL FILLING PIPE WITH FLANGED COVER
7	1	TOP COVER WITH LIFTING LUGS (x2)
6	1	OIL LEVEL GAUGE (with 15°) COLD OIL LEVEL MARK
5	1	SILICA GEL BREATHER TYPE R
4	2	EARTHING TERMINAL (FLAT TYPE suitable for M12 Bolt)
3	1	TRANSFORMER BASE (SKID TYPE) c/w HAULAGE HOLES & BRACING
2	1	LV CABINET, BOTTOM ENTRY, GENERIC MODEL - SUBJECT TO CHANGE, (FACING-'F', BS:2562)
1	1	HV CABLE BOX - 12KV, 3-POLE, HEAT-SHRINK INSULATION, (FACING-'E' BS:2562) SUITABLE FOR 1 x 3c CABLE - MAX. 185mm.sq

ESSENTIAL LABELS

- ITEM 10 TAP CHANGER WARNING LABEL
- ITEM 6 COLD COOLANT LEVEL
- ITEM 2 LV WARNING LABEL
- ITEM 1 HV WARNING LABEL

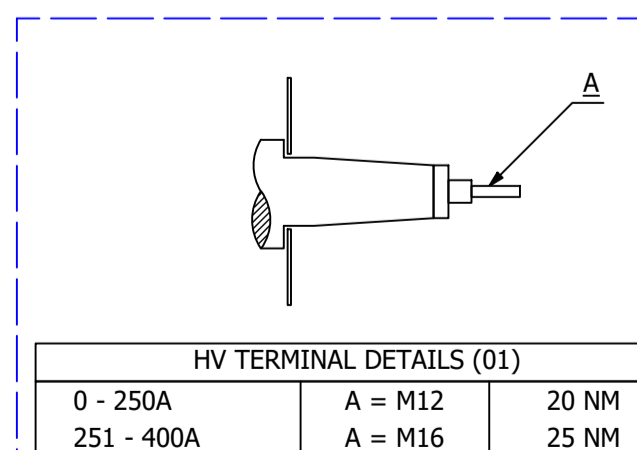

- GENERAL NOTES
- ALL DIMENSIONS ARE IN 'mm'.
 - ALL DIMENSIONS/WEIGHTS ARE SUBJECT TO ± 10% TOLERANCE.
 - ELECTRONIC SCALE - 1:1 (ONLY WRITTEN DIMENSIONS TO BE FOLLOWED).
 - TOLERANCE ON IMPEDANCE PER IEC:60076.
 - PAINT SHADE.: 632 As PER BS:381C (SEMI GLOSS) TO ISO12944 - MIN C4H SPEC.
 - O/ALL DIMS ARE SUBJECT TO EQUIPMENT DOOR OPENING DISTANCES.

IF IN DOUBT - ASK. REMOVE ALL SHARP EDGES. DO NOT SCALE. DRAWING NOT TO SCALE

REV	REV BY	VERIFIED	APPROVED	DESCRIPTION

REVISION DESCRIPTION	REV	PROJECT
ORIGINAL	00	CUSTOMER
		S.O. NUMBER
		P.O. NUMBER
		W.O. NUMBER

DRAWING TITLE	DRAWN BY:
GENERAL ARRANGEMENT DRAWING FOR 315kVA WILSON e4 AMORPHOUS ULTIMATE LOW LOSS 11000/415V, 50Hz, Dyn11, ONAN AL WOUND DISTRIBUTION TRANSFORMER LV CABINET	J. PHILBRICK
	DATE:
	28/05/2024
	DRAWING NO.:
	WPS-E4-315-AL-A001

WILSON POWER SOLUTIONS
Westland Square, Leeds
West Yorkshire LS11 5SS, United Kingdom
Tel: +44 (0) 113 271 7588
Fax: +44 (0) 113 277 5124
web: www.wilsonpowersolutions.co.uk email: info@wilsonpowersolutions.co.uk

WPS-E4-315-AL-A001 SHEET 1 OF 1