

VIEW ON HV SIDE
PHASE ROTATION
1U 1V 1W

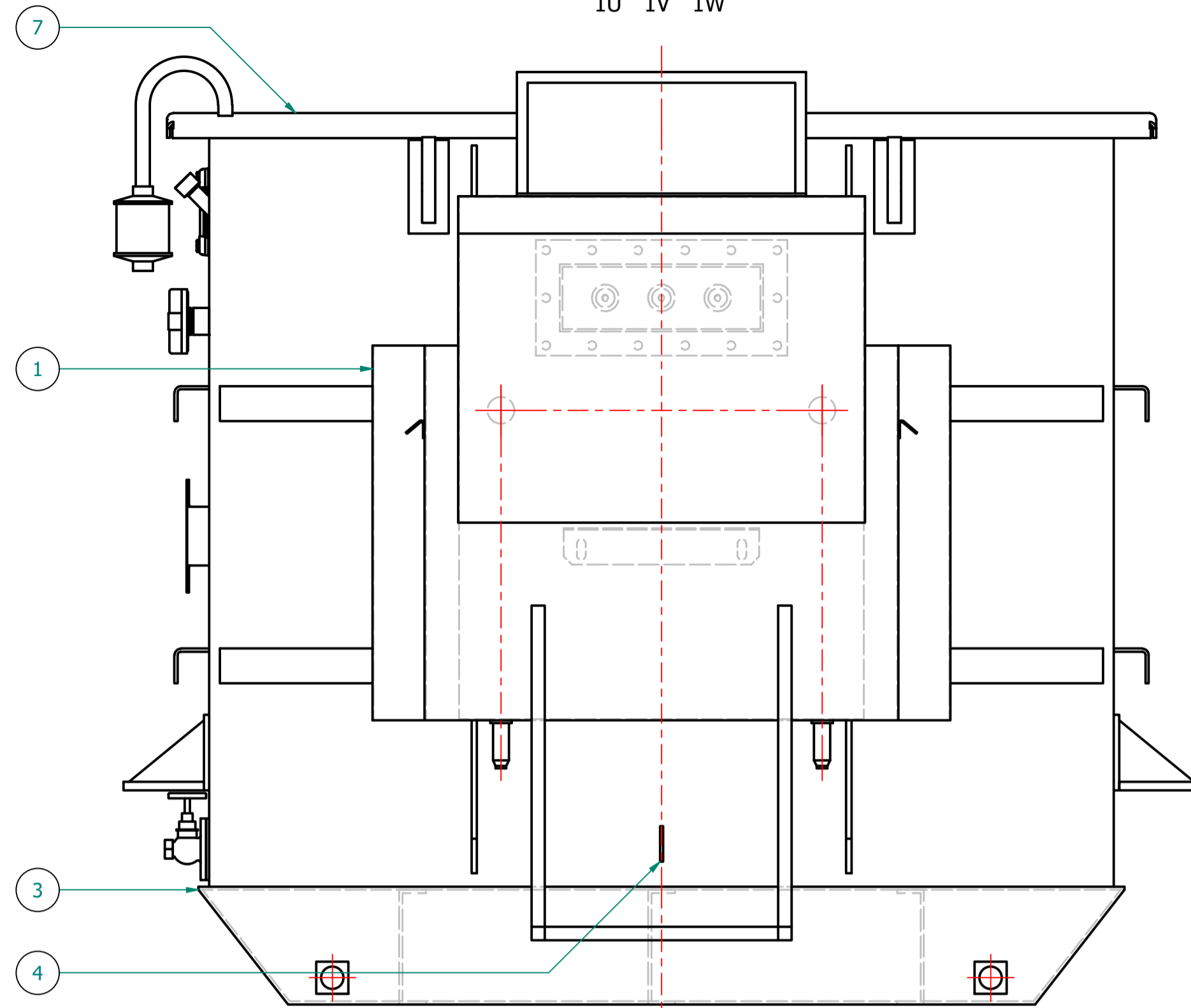

VIEW ON TAP SWITCH END

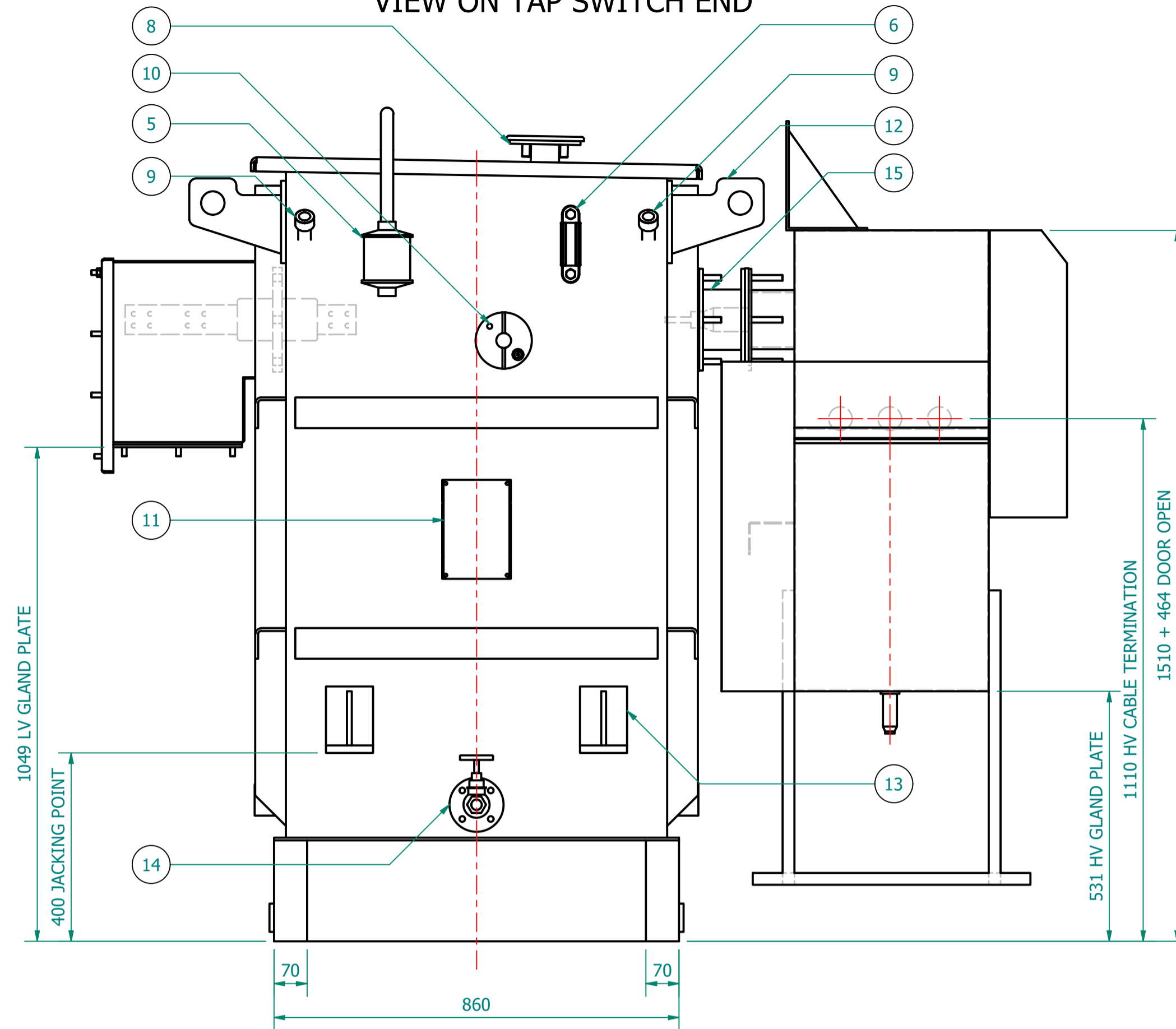

VIEW ON LV SIDE
PHASE ROTATION
2W 2V 2U 2N

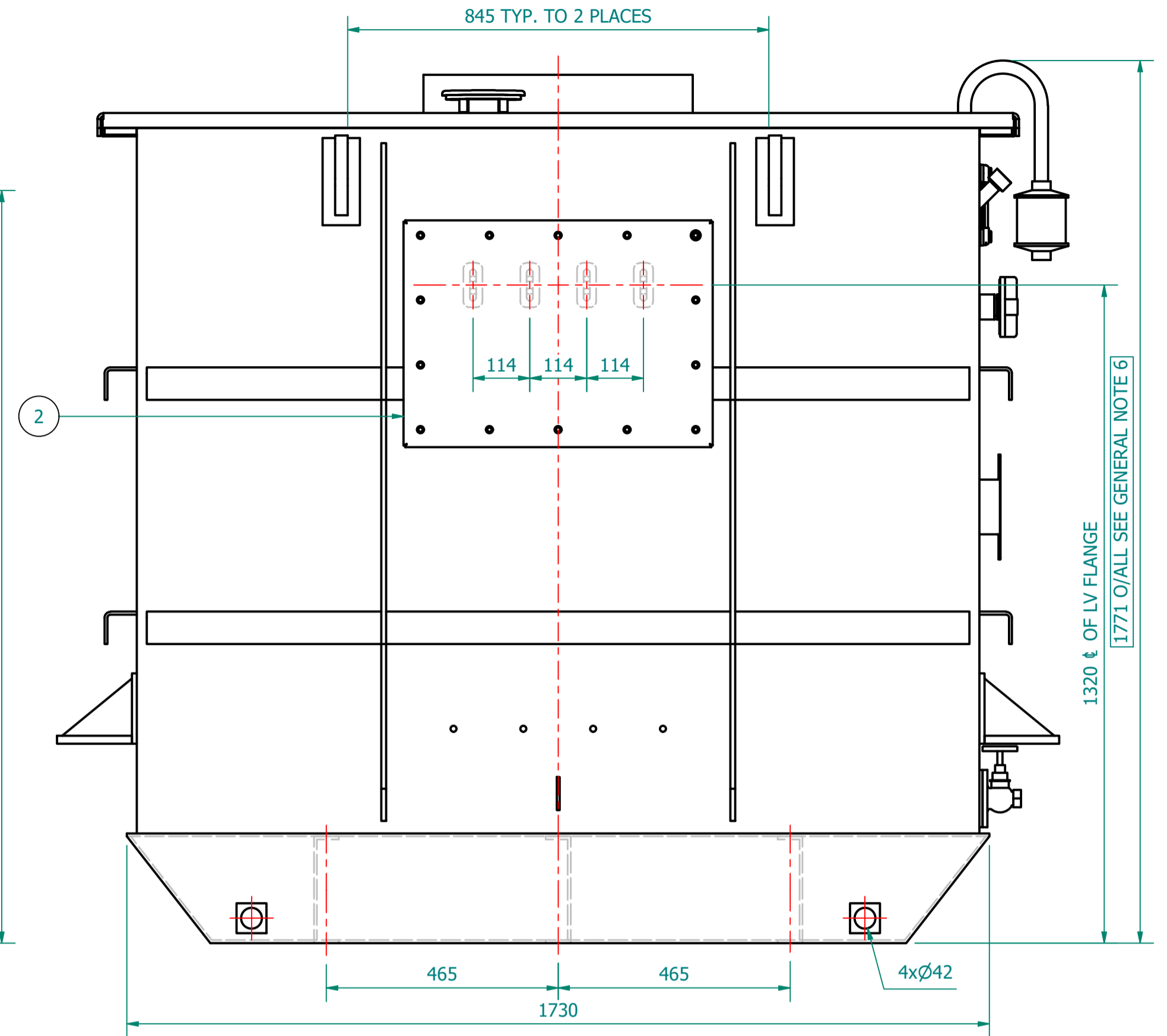

PLAN VIEW
2028 O/ALL

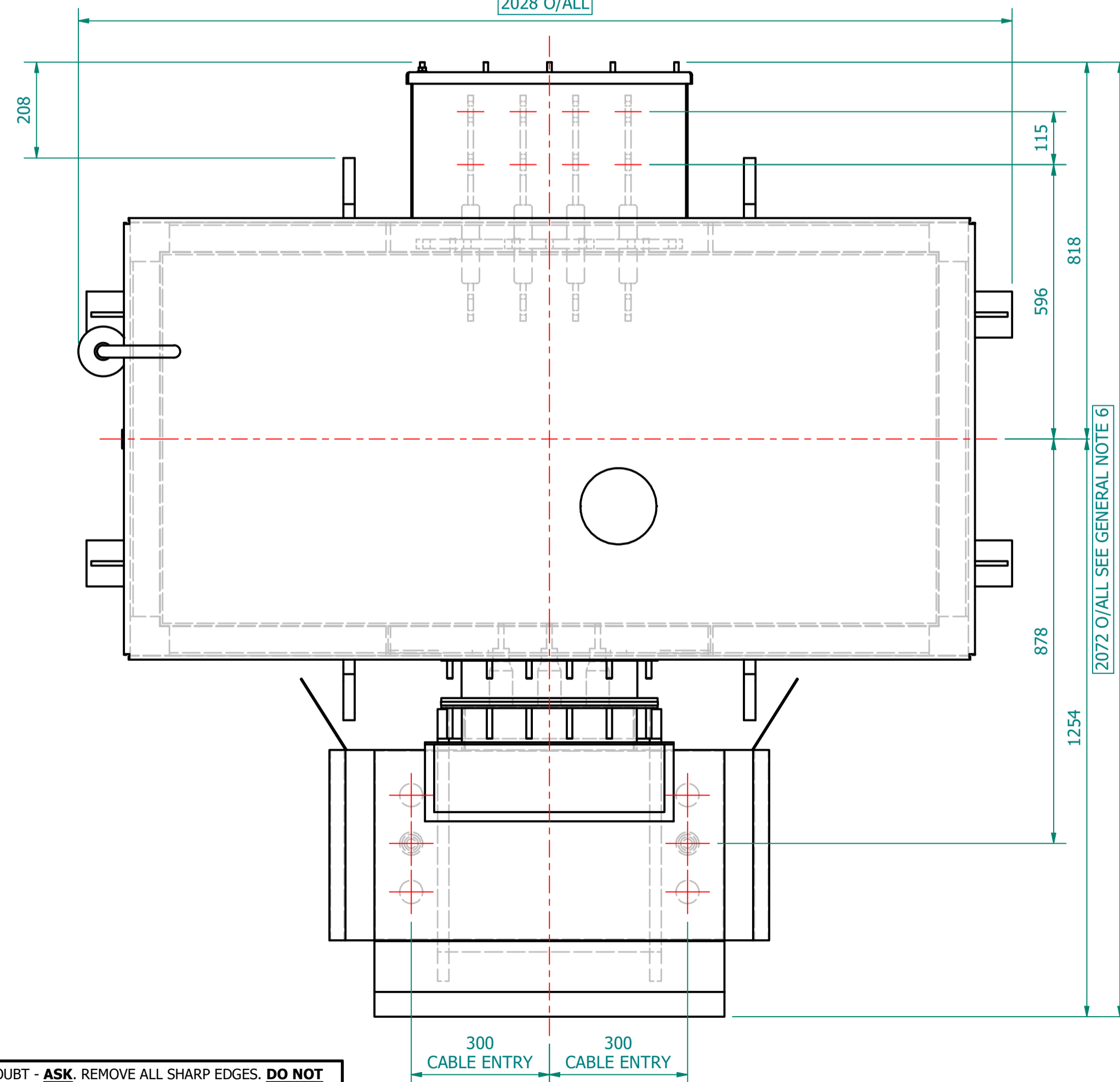

TRANSFORMER WEIGHT & VOLUME	
CORE AND WINDING	kg 2640
TANK AND FITTING	kg 800
COOLING LIQUID VOLUME	L 1155
COOLING LIQUID WEIGHT	kg 940
TOTAL TX WEIGHT	kg 4380
ADDITIONS TO THE TRANSFORMER WEIGHT	
RN2d RMU	Kg 385

VIEW OF LV SIDE - CABLE CLEAT STUDS
CABLES MUST BE SUPPORTED IN ACCORDANCE WITH -
CURRENT IET Wiring Regulations BS7671 & IEC 61914

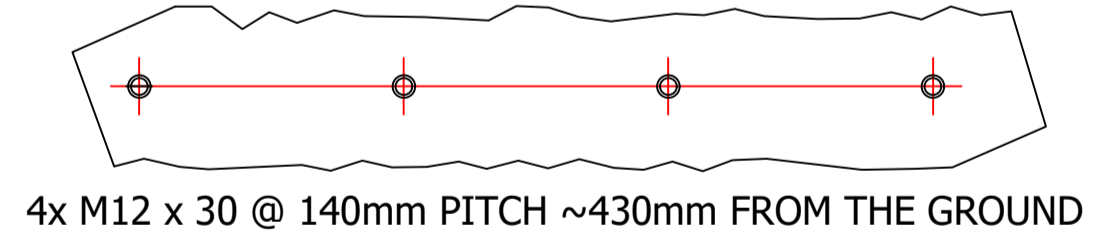

ESSENTIAL LABELS

- ITEM 10 TAP CHANGER WARNING LABEL
- ITEM 6 C.O.L. 15°C COLD COOLANT LEVEL
- ITEM 2 LV WARNING LABEL
- ITEM 1 HV WARNING LABEL

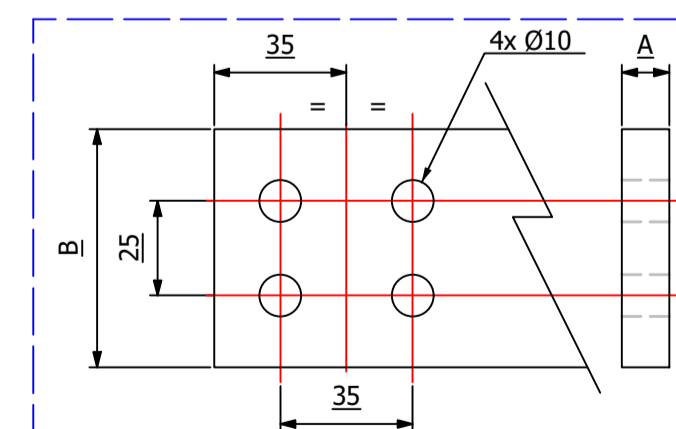

LV TERMINAL DETAILS (02)		
1700A	A = 12.5 mm	B = 63 mm
2500A	A = 20 mm	B = 63 mm
3150A	A = 35 mm	B = 63 mm
4000A	A = 35 mm	B = 70 mm

800kVA		ELECTRICAL RATINGS			
No Load Voltage Ratio at Normal Tap	HV Tappings	Vector Group	Frequency	Full-Load Current at Normal Tap	
11000 / 415V	+7.5 to -5.0% IN 2.5% INCREMENTS	Dyn11	50Hz	HV Side	LV Side
Design Impedance at Normal Tap	No Load Losses at rated Voltage & Frequency	Full Load Losses at rated Current & at 75°C Temp.	Temp. Rise above Ambient 40°C		
4.75%	425W	4265W	in Oil by Therm.	in Wdg. by Res.	
			60°C	65°C	

- GENERAL NOTES
- ALL DIMENSIONS ARE IN 'mm'.
 - ALL DIMENSIONS/WEIGHTS ARE SUBJECT TO ± 10% TOLERANCE.
 - ELECTRONIC SCALE - 1:1 (ONLY WRITTEN DIMENSIONS TO BE FOLLOWED).
 - TOLERANCE ON IMPEDANCE PER IEC:60076.
 - PAINT SHADE.: 632 As PER BS:381C (SEMI GLOSS) TO ISO12944 - MIN C4H SPEC.
 - O/ALL DIMS ARE SUBJECT TO EQUIPMENT DOOR OPENING DISTANCES.

ITEM	QTY	DESCRIPTION
15	1	HV THROAT
14	1	DRAIN VALVE (25NB) with MALE PLUG
13	4	JACKING PADS
12	4	TRANSFORMER LIFTING LUGS
11	1	RATING & DIAGRAM PLATE (SS)
10	1	OFF-CIRCUIT TAP SWITCH (6-Position & Padlockable)
9	2	THERMOMETER POCKET (3/4" BSP MALE THREAD)
8	1	OIL FILLING PIPE WITH FLANGED COVER
7	1	TOP COVER with LIFTING LUGS (x2)
6	1	OIL LEVEL GAUGE (with 15°) COLD OIL LEVEL MARK
5	1	SILICA GEL BREATHER TYPE R
4	2	EARTHING TERMINAL (FLAT TYPE suitable for M12 Bolt)
3	1	TRANSFORMER BASE (SKID TYPE) c/w HAULAGE HOLES & BRACING
2	1	LV CABLE BOX - 1.1kV, 4-POLE, AIR INSULATION, (FACING-'F', BS:2562) SUITABLE FOR 2 x 1c CABLES PER PHASE & N - MAX. 630mm.sq
1	1	HV RMU - 11kV, 200A, GCB, 630A BUS [Schneider RN2d-T1/21] TLF PROTECTION, (FACING-'E' BS:2562)

IF IN DOUBT - ASK. REMOVE ALL SHARP EDGES. DO NOT SCALE. DRAWING NOT TO SCALE

	REVISION DESCRIPTION ORIGINAL	REV 00	PROJECT CUSTOMER	DRAWING TITLE GENERAL ARRANGEMENT DRAWING FOR 800kVA WILSON e4 AMORPHOUS ULTIMATE LOW LOSS 11000/415V, 50Hz, Dyn11, ONAN AL WOUND DISTRIBUTION TRANSFORMER RN2d RMU	DRAWN BY: J. PHILBRICK	
	REV. BY: J. PHILBRICK VERIFIED: APPROVED:	DATE 28-MAY-2024	P.O. NUMBER W.O. NUMBER	DATE: 28/05/2024	DRAWING NO.: WPS-E4-800-AL-A002	